

200 Series Double Combination

ADR
Approved

IP67
Protection

5 Year
Warranty

- Surface Mount
- Popular Design
- IP67 100% Waterproof
- ADR approved
- 5 Year Warranty

Function (Stop/Tail) (Indicator)
Size 200mm x 92mm x 28mm
Voltage 12-24 Volt
LED Qty 72
Cable 40cm cable

Draw	Stop	Tail	Ind
@13.8V	0.32A	0.04A	0.34A
@28V	0.18A	0.04A	0.19A

Approvals	Function	Category	CTA
ADR	Stop/Tail	49/00	CTA-060095
ADR	Indicator	6/00 2a	CTA-060095

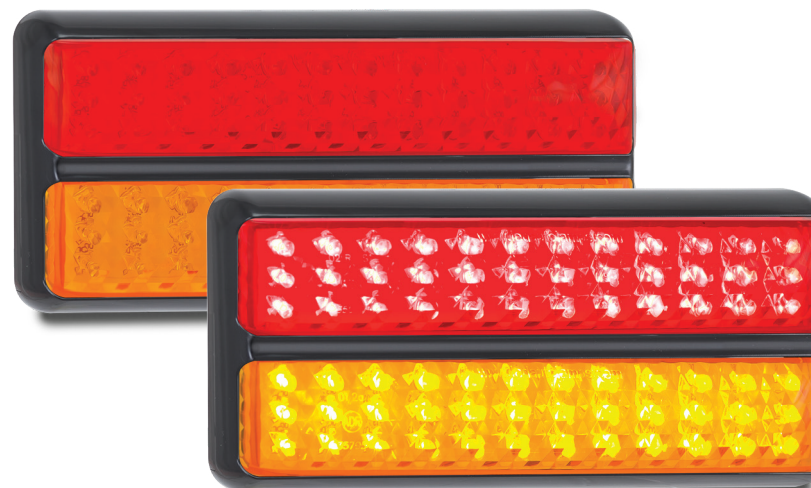

Stop/Tail/Indicator
200BARM - Blister

Active

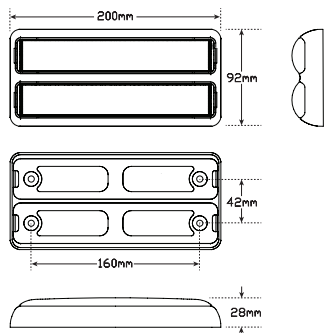

Fitting Instructions

Surface mount bracket onto flat surface horizontally with bolts provided, run wires through back and clip lens into place. Please refer to ADR 13/00.



All enquiries P: 1800 815 000 E: led@ledautolamps.com.au, www.ledautolamps.com

All efforts are made to ensure all information is correct and up to date, it can be subject to change without notice. All measurements are in millimeters (mm) and are not to scale. All LED Autolamps designs are registered throughout the world. - Current as of 26/10/2023