



autolamps

A Clarience Technologies Company

**CABLE HARNESS
& LIGHTING SYSTEM**

Version 6.2 - March 2026

Functional, Long Lasting Quality

Innovative Harness System

The key to this system is its flexibility, offering every conceivable option for various lighting functions to be added at any point in the truck harness line.

Flexibility/Versatility

Cable lengths range from 0.25m to 15m combined with heavy duty connector covers for every plug and connector assembly point with a breaking strain exceeding 25kg, making this a heavy duty and robust truck harness assembly.

Colour Coded

All assembly plugs are colour coded to their specific function. Example - The Brown plug is for Marker Lamps. When requiring a marker lamp, add a brown plug in the harness line. The Yellow (LHS) or Green (RHS) plug is for Side Direction Indicator Lamps. When requiring a Side Direction Indicator lamp, add a yellow or green plug whether left or right hand side in the harness line.

DG Rating & Road Train

Cables and covers manufactured to comply with DG (Dangerous Goods) Rating. Inspected by Worksafe Victoria and in accordance with DG-150424-1, DG-150424-2 in relation to the electrical wiring requirements as it applies to dangerous goods road vehicle bulk tankers, in accordance for usage with petrol and gas tankers. Cabling and lighting comply with AS2809 parts 1 & 2. You can achieve *Road Train Compatibility to ADR 63/00 on all drawings using the 7 Core (6mm) RTC cable & plugs.* See Page 6 & 48-49 for more information.

Labour Costs

Designed specifically to be easily and quickly installed without the need to cut, splice, solder, join or tape wire joins, reducing fitting times with its simple plug in design. Expect to reduce lighting assembly labour costs by up to 75%.

Warranty

Five year warranty for all truck & trailer vehicles and a one year warranty for livestock carrying trailers.

Plugin Cables
Page 8-12



Lighting
Page 13-22



Plugs/Covers
Page 23-27



7P Trailer Sockets
Page 28-29



Skel/Semi Trailer
Page 30-31



- **Add any Light Anywhere in the Harness System**
- **Easily Replace Damaged Lighting with Minimal Downtime**
- **Heavy Duty Water-resistant Cable, Plugs and Connectors**
- **Colour Coded Plugs to the Colour of the Wire Function**
- **All Large Vehicles and Trailers**
- **All Lights Compliant with ECE or ADR**
- **Cable System Compliant with Dangerous Goods (AS2809)**
- **All Drawings Compatible with Road Train (Page 6 & 48-49)**
- **5 Year Warranty, Livestock Transport 1 Year Warranty**
- **RoHS Compliant Cables, Plugs and Lights**

Cable and Wire

TWP Cable (Thin wall thermo plastic) and PVC Automotive primary wire complying with SA-J1128, Annealed copper wire in compliance with ASTMB3, RoHS compliant Lead free copper wire with operating temperature between -40°C to +85°C - Harness system tested to B-Double requirements when LEDs are used. Please refer to wire gauge table below for further information regarding wire gauge and amperage.

Function	Wire Colour	Gauge	Rated Amp	Draw @13.8V	Maximum Lamps	Diameter (mm)	Area (mm ²)	Resistance (Ohms/1000ft)
Earth	White	14	20	-	-	1.62814	2.08	2.525
Accessory	Blue	16	10	2.0A	-	1.29032	1.31	4.016
Stop	Red	18	8	0.47A	16 Lamps	1.02362	0.823	6.385
Left Indicator	Yellow	20	5	0.42A	10 Lamps	0.8128	0.518	10.15
Right Indicator	Green	20	5	0.42A	10 Lamps	0.8128	0.518	10.15
Marker	Brown	20	5	0.05A	120 Lamps	0.8128	0.518	10.15
Reverse	Black	20	5	0.59A	8 Lamps	0.8128	0.518	10.15

Refrigerated/Curtainsider
Page 32-37



A&B Coupling/Dolly/Tag
Page 38-39



Tanker/Trailer
Page 40-41



Rigid/Tilt/Tipper
Page 42-45



Drop Deck/Road Train
Page 46-49



Australian First Dual Function Marker/Indicator Lamp

Introducing the All-New 97 series side marker/indicator combination lamp, which is Australian road approved for Category five side direction indicator as well as an amber/red side marker. The lamps are large trailer plugin harness compatible, enabling them to be easily daisy-chained down the length of the vehicle or incorporated into existing harness setup. Adaptability allows you to add any combination of marker lamps or marker/indicator lamps.

The standard function is an amber/red side marker. The override function is the side direction indicator. When the indicator is active, the marker is disabled. The Front and Rear end outline markers include supplementary indicators which are not ADR.



Front Marker Indicator Lamp
Page - 20
Part No. 97WIMCSB
Front End Outline Marker
Supplementary Indicator



Rear Marker Indicator Lamp
Page - 20
Part No. 97RIMCSB
Rear End Outline Marker
Supplementary Indicator

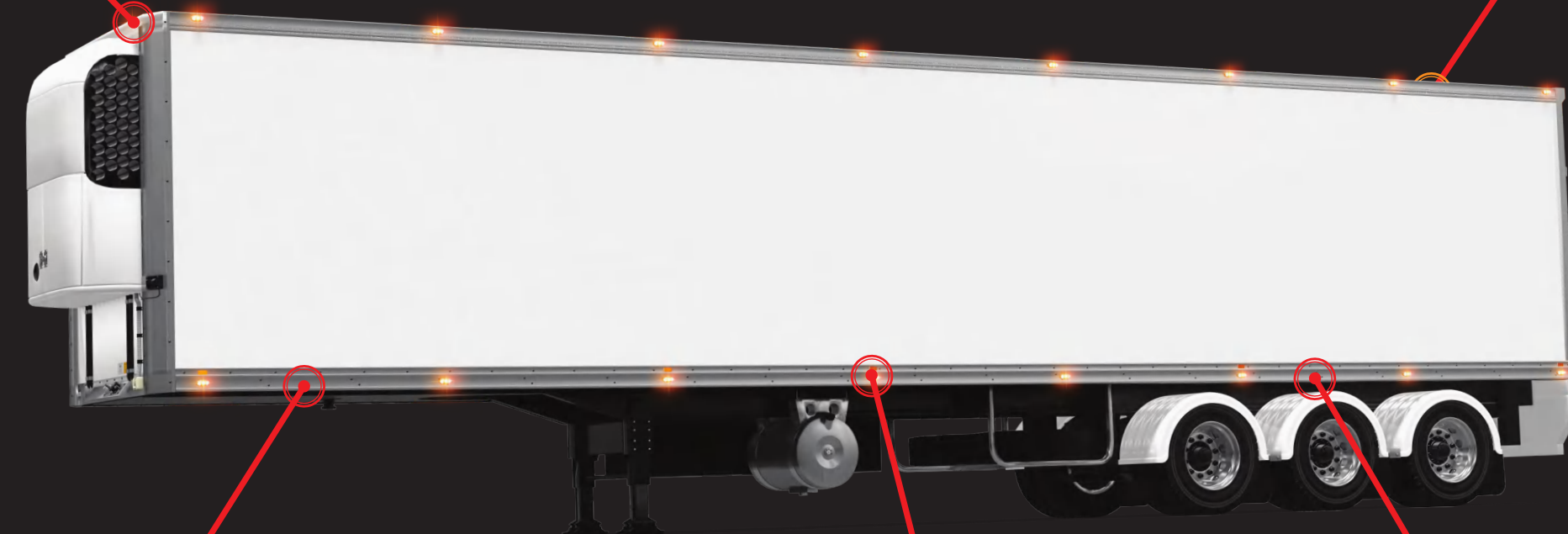

LHS/RHS Indicator Splitter
Page - 25
Part No. 7CILR3B
Combination Left
and Right Indicator



Side Marker Indicator Lamp
Page - 20
Part No. 97ARIMCSB
Amber/Red Side Marker
Side Direction Indicator



Marker Indicator Splitter
Page - 25
Part No. 3P3IMB
3 Core 3 Way
Indicator Splitter

Single Function Lamp Adaptability Or Additional Lamps From Main Cable

Many customers still prefer to use the recessed type rectangle or round lights for their trailer builds. The 7CFS series of plugs allows this to happen by splitting from the main cable a series of individual cables and plugs to suit Stop/Tail Lamps, Indicator Lamps and Reverse Lamps.

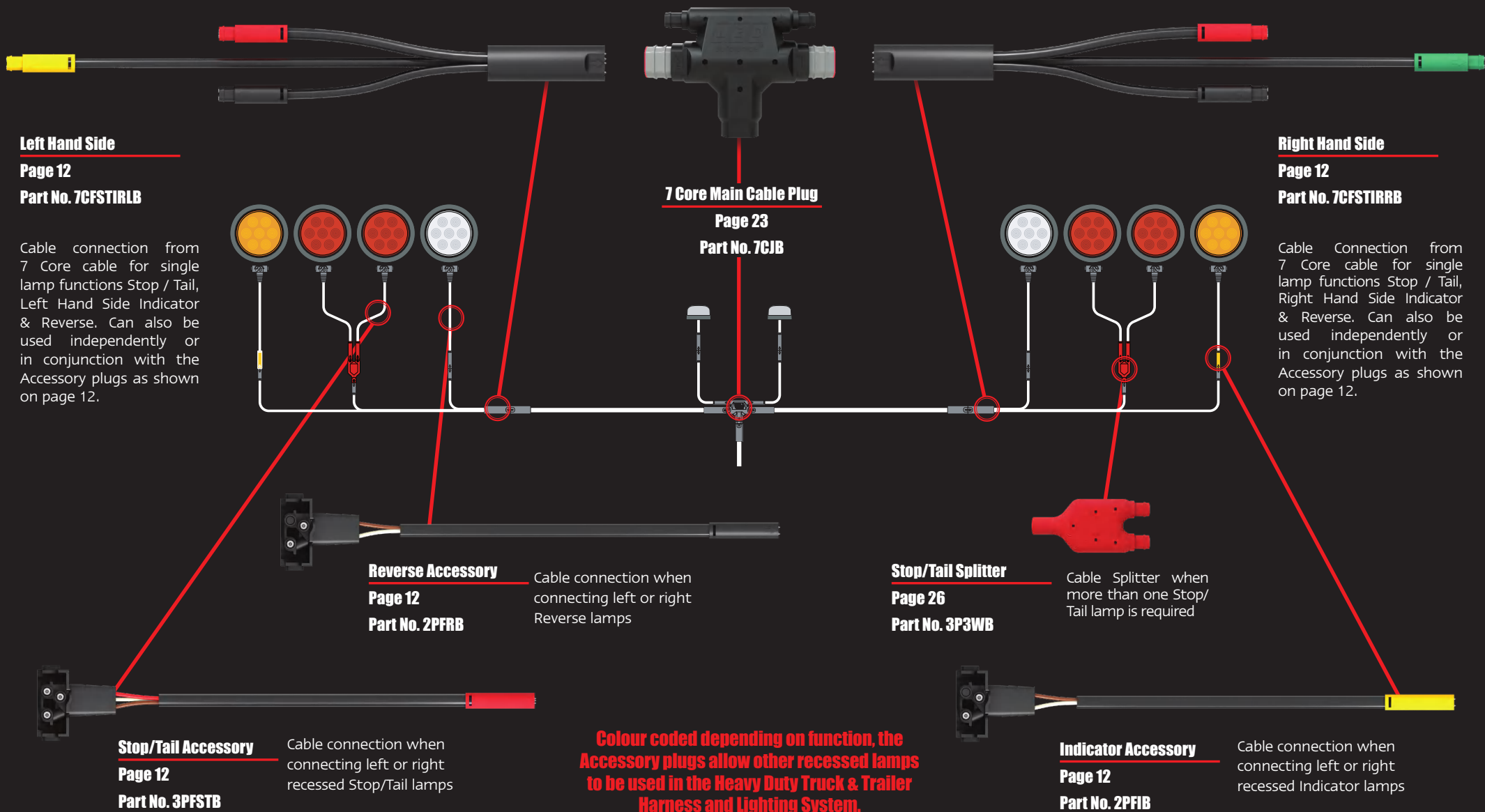

Left Hand Side

Page 12

Part No. 7CFSTIRLB

Cable connection from 7 Core cable for single lamp functions Stop / Tail, Left Hand Side Indicator & Reverse. Can also be used independently or in conjunction with the Accessory plugs as shown on page 12.

Right Hand Side

Page 12

Part No. 7CFSTIRRB

Cable Connection from 7 Core cable for single lamp functions Stop / Tail, Right Hand Side Indicator & Reverse. Can also be used independently or in conjunction with the Accessory plugs as shown on page 12.

7 Core Main Cable Plug

Page 23

Part No. 7CJB

Reverse Accessory

Page 12

Part No. 2PFRB

Cable connection when connecting left or right Reverse lamps

Stop/Tail Splitter

Page 26

Part No. 3P3WB

Cable Splitter when more than one Stop/Tail lamp is required

Stop/Tail Accessory

Page 12

Part No. 3PFSTB

Cable connection when connecting left or right recessed Stop/Tail lamps

Indicator Accessory

Page 12

Part No. 2PFIB

Cable connection when connecting left or right recessed Indicator lamps

Colour coded depending on function, the Accessory plugs allow other recessed lamps to be used in the Heavy Duty Truck & Trailer Harness and Lighting System.

Road Train Adaptability to ADR 63/00 Vehicle Standards



Part No.	Cable Function	(See Page 46-47)
690-1062-01	6 METRES RETRACTABLE	
690-1062-02	10 METRES RETRACTABLE	
690-1063-01	5 METRES RETRACTABLE	
690-1063-02	3 METRES RETRACTABLE	
690-1064-01	DOLLY 5 METRES	
690-1065-01	ROADTRAIN HARNESS 14.5 METRES	
690-1065-02	ROADTRAIN HARNESS 15.5 METRES	
690-1065-03	ROADTRAIN HARNESS 16 METRES	
690-1065-04	ROADTRAIN HARNESS 13 METRES	

ROAD TRAIN CABLE PART
NUMBERS DO NOT INCLUDE
PLUGS OR SOCKETS.

PLEASE REFER TO PAGE
28 AND 30 FOR MORE
INFORMATION.



Trailer compliance for use in road train is made possible with our range of Road Train Cables. We use a 7 Core (6mm) RTC cable that's Australian made, conforms to applicable standards and is professionally adapted to our cable harness and lighting system. Both options available have a total extended length of 5m, 13m, 14.5, 15.5m and 16m respectively and use high-quality 12V, ISO 1724 and 24V, ISO 1185/DIN 7579 corrosion-resistant aluminium 7 Pin sockets. The standard system also offers 2 Core and 7 Core harness plugs, whilst the Dropdeck cabling is suited to retractable skeletal trailers when combined with a retractable Suzi cable (See page 26/27). It also includes our cable harness and lighting system 7 Core plugs.

Specifications

- 6.0mm Seven Core Cable Black Sheath
- PVC Insulation to AS3191
- Voltage Rating up to 110V
- Strand Diameter: 0.3mm
- Number of Strands: 65
- Conductor Cross Section: 5.22mm²
- Wire Colours: Green, Yellow, Blue, Red, White, Black, Brown



•ROHS •V90 •OXYGEN FREE •LEAD FREE PVC - E.L.V. ONLY

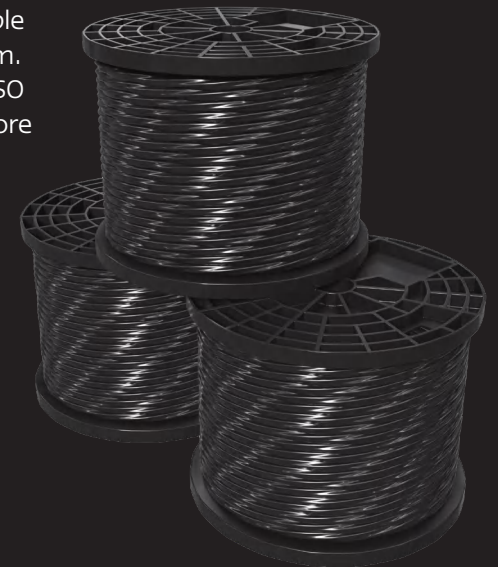

Power Patch Cables For Vehicle Lighting

The Rigid body trucks can also benefit from this system with many possibilities to advance your lighting and wiring options. We now offer a range of Power Patch Cables that taps into the vehicle's existing rear lighting harness, enabling the addition of markers, high-level combination lamps or trailer sockets without time-consuming wiring. This innovative system will give you the flexibility and adaptability to compliment your O/E fitting requirements saving you time and money.

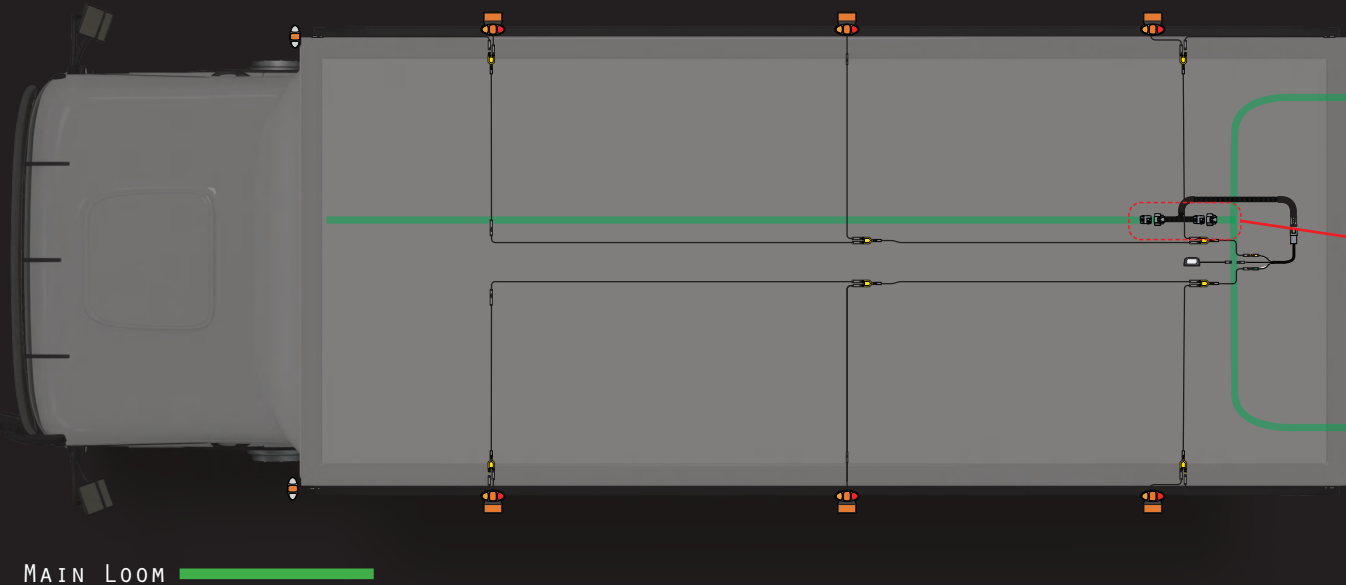

- Perfect for OEM Fitters
- Save Time & Money
- System Expandable
- System Customisable
- System Adaptability

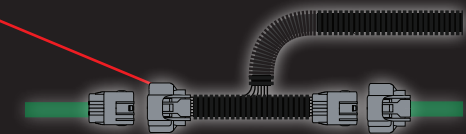

PATCHING INTO THE EXISTING LOOM USING A PPATCH POWER HARNESS

We have break-out patch cables to suit many Rigid Truck Brands. If you require a specific application, please call us to discuss your requirements.



Detailed Explanation in Our Patch Harness Catalogue on page 40-63



7 Core Cables with Male & Female Plugs

The cable we have chosen for this harness system is used widely in the automotive industry and complies with SA-J1128 Standards. The cable width is 9.5mm, Male & Female plug diameter is 18mm. The plugs we have designed are 100% water-resistant, with a unique double sealing lip that will not allow water ingress. The covers for the plugs have been created for extra strength and engineered to a breaking strain of 25kg. The connection cover ensures a secure fitment and completes Dangerous Goods Rating AS2809.

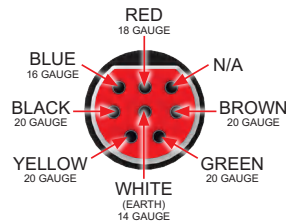

Part No. Size
CMCB | 110MM x 24MM

JOINED PLUG IN COVER



BREAKING STRAIN 25KG

Part No.	Length
7CMF.25B	25 CENTIMETRES
7CMF.5B	50 CENTIMETRES
7CMF1B	1 METRE
7CMF1.5B	1.5 METRE
7CMF2B	2 METRE
7CMF2.5B	2.5 METRE
7CMF3B	3 METRE
7CMF4B	4 METRE
7CMF5B	5 METRE
7CMF6B	6 METRE
7CMF8B	8 METRE
7CMF10B	10 METRE
7CMF15B	15 METRE

2 Core Cables with Male & Female Plugs or Female Plugs with Bare Wires

The cable we have chosen for this harness system is used widely in the automotive industry and complies with SA-J1128 Standards. The cable width is 6mm, Male & Female plug diameter is 9mm. The plugs we have designed are 100% water-resistant, with a sealing lip that will not allow water ingress. The covers for the plugs have been created for extra strength and engineered to a breaking strain of 15kg. The connection cover ensures a secure fitment and completes Dangerous Goods Rating AS2809.



Part No.	Length
2PMF.25B	25 CENTIMETRES
2PMF.5B	50 CENTIMETRES
2PMF1B	1 METRE
2PMF1.5B	1.5 METRE
2PMF2B	2 METRE
2PMF2.5B	2.5 METRE
2PMF3B	3 METRE
2PMF4B	4 METRE
2PMF5B	5 METRE



Part No.	Length
2PF.25B	25 CENTIMETRES
2PF.5B	50 CENTIMETRES
2PF1B	1 METRE

JOINED PLUG IN COVER



BREAKING STRAIN 15KG

CABLE PLUG COVER



Part No. Size
2PCB | 72MM x 15MM

3 WAY SPLITTER
FOR 2 CORE CABLE



Part No. Length
2PMF3WB | 85MM
2PMF3W.9B | 95MM



2 CORE CABLE TO SUIT
REVERSE BEEPERS

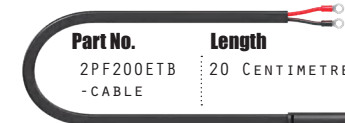

Part No. Length
2PF200ETB
-CABLE | 20 CENTIMETRES

7 Core Cables with Male Plug and Bare Wires

The cable we have chosen for this harness system is used widely in the automotive industry and complies with SA-J1128 Standards. The cable width is 9.5mm, Male plug diameter is 18mm. The plugs we have designed are 100% water-resistant, with a unique double sealing lip that will not allow water ingress. The covers for the plugs have been created for extra strength and engineered to a breaking strain of 25kg. The connection cover ensures a secure fitment and completes Dangerous Goods Rating AS2809.

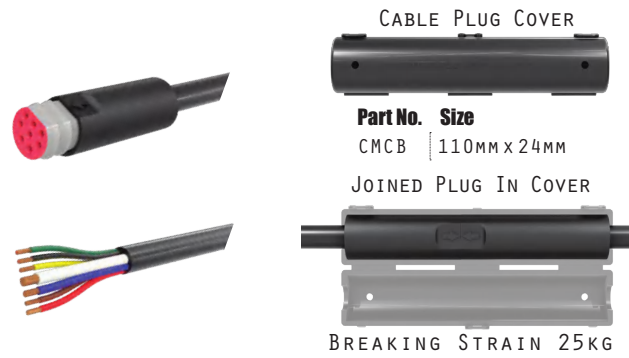
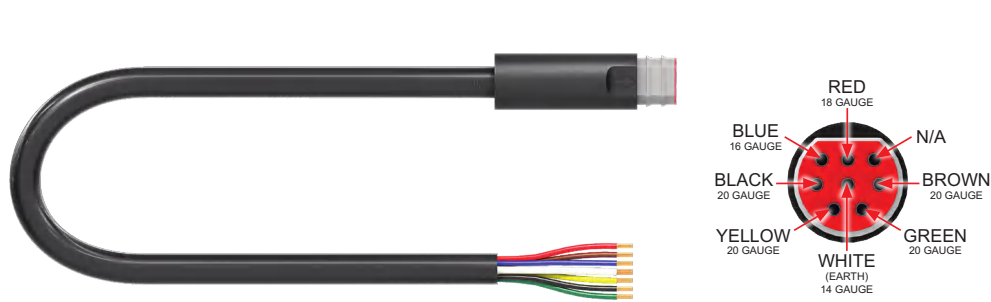

Part No.	Size
CMB	110MM x 24MM

Part No.	Length
7CM1B	1 METRE
7CM2B	2 METRE
7CM3B	3 METRE

3 Core Cables with Male & Female Plugs

The cable we have chosen for this harness system is used widely in the automotive industry and complies with SA-J1128 Standards. The plugs we have designed are 100% water-resistant, with a sealing lip that will not allow water ingress.

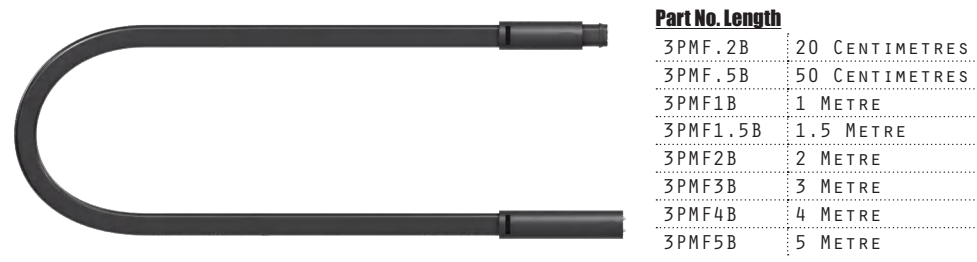

Part No.	Length
3PMF.2B	20 CENTIMETRES
3PMF.5B	50 CENTIMETRES
3PMF1B	1 METRE
3PMF1.5B	1.5 METRE
3PMF2B	2 METRE
3PMF3B	3 METRE
3PMF4B	4 METRE
3PMF5B	5 METRE

16 Gauge Cables for the Accessory Blue Wire

The heavy-duty truck harness system has provisions for an accessory product fitted via the 16 gauge blue wire. Plugin one of the adapter plugs into the harness system, then run a 2 Core cable to connect an accessory product.

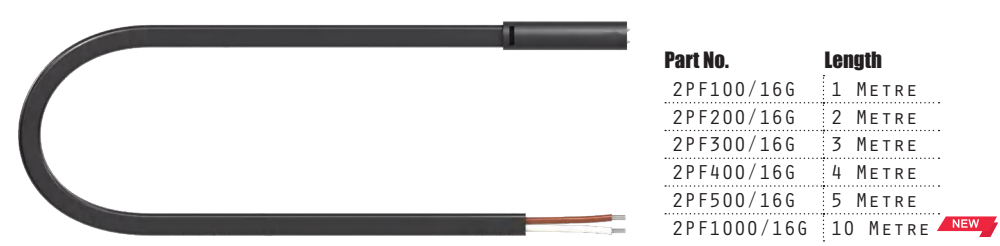

Part No.	Length
2PF100/16G	1 METRE
2PF200/16G	2 METRE
2PF300/16G	3 METRE
2PF400/16G	4 METRE
2PF500/16G	5 METRE
2PF1000/16G	10 METRE NEW

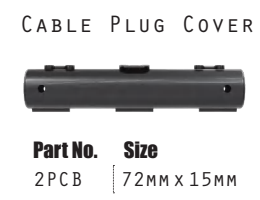
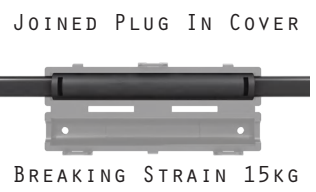

Important Note; Work lights on the harness system are an accessory and should be connected to the blue wire and not the reverse (black) wire. The maximum size work lamps allowable on the blue wire are 120 watts in a 12 volt system and 240 watts in a 24 volt system. If you need to run work lamps at the same time as the reverse light then the blue wire can be connected to the reverse wire at the front of the trailer.

7 Core Cables Plug to DT6S Connectors



Introducing our new 7 Core Cables with 7PF Large Harness System Plug and DT6S Deutsch Plug—engineered for durability and versatility. These water-resistant cables are fully compatible with the Large Harness Systems and adapt Deutsch connectors seamlessly. Available in 2 lengths ranging from 25cm and 1 metre with left and right hand sides, they offer flexible solutions for a wide range of applications. Built tough for performance, these cables are ready to power your next project.



Part No.	Description	Length
7PFCSB-DT6SL.25-E	LEFT TAIL,7PF PLUG TO DT6S,0.25M	25 CENTIMETRES
7PFCSB-DT6SL1-E	LEFT TAIL,7PF PLUG TO DT6S,1.0M	1 METRE
7PFCSB-DT6SR.25-E	RIGHT TAIL,7PF PLUG TO DT6S,0.25M	25 CENTIMETRES
7PFCSB-DT6SR1-E	RIGHT TAIL,7PF PLUG TO DT6S,1.0M	1 METRE

2 Core Cables with 2PF to DT2S Connectors



Introducing our new 2 Core Cables with 2PF Large Harness System Plug and DT2S Deutsch Plug—engineered for durability and versatility. These water-resistant cables are fully compatible with the Large Harness Systems and adapt Deutsch connectors seamlessly. Available in 11 lengths ranging from 25cm to 5 metres, they offer flexible solutions for a wide range of applications. Built tough for performance, these cables are ready to power your next project.



Part No.	Description	Length
2PFCSB-DT2S.25	2PF PLUG TO DT2S,0.25M	25 CENTIMETRES
2PFCSB-DT2S.5	2PF PLUG TO DT2S,0.5M	50 CENTIMETRES
2PFCSB-DT2S1	2PF PLUG TO DT2S,1.0M	1 METRE
2PFCSB-DT2S1.5	2PF PLUG TO DT2S,1.5M	1.5 METRE
2PFCSB-DT2S2	2PF PLUG TO DT2S,2.0M	2 METRE
2PFCSB-DT2S2.5	2PF PLUG TO DT2S,2.5M	2.5 METRE
2PFCSB-DT2S3	2PF PLUG TO DT2S,3.0M	3 METRE
2PFCSB-DT2S3.5	2PF PLUG TO DT2S,3.5M	3.5 METRE
2PFCSB-DT2S4	2PF PLUG TO DT2S,4.0M	4 METRE
2PFCSB-DT2S4.5	2PF PLUG TO DT2S,4.5M	4.5 METRE
2PFCSB-DT2S5	2PF PLUG TO DT2S,5.0M	5 METRE

3 Core Cables with 3PF to DT4S Connectors **NEW**

Introducing our new 3 Core Cables with 3PF Large Harness System Plug and DT4S Deutsch Plug—engineered for durability and versatility. These water-resistant cables are fully compatible with the Large Harness Systems and adapt Deutsch connectors seamlessly. Available in 11 lengths ranging from 20cm to 5 metres, they offer flexible solutions for a wide range of applications. Built tough for performance, these cables are ready to power your next project.



Part No.	Description	Length
3PFCSB-DT4S.2-E	3PF PLUG TO DT4S,0.2M	20 CENTIMETRES
3PFCSB-DT4S.5-E	3PF PLUG TO DT4S,0.5M	50 CENTIMETRES
3PFCSB-DT4S1-E	3PF PLUG TO DT4S,1.0M	1 METRE
3PFCSB-DT4S1.5-E	3PF PLUG TO DT4S,1.5M	1.5 METRE
3PFCSB-DT4S2-E	3PF PLUG TO DT4S,2.0M	2 METRE
3PFCSB-DT4S2.5-E	3PF PLUG TO DT4S,2.5M	2.5 METRE
3PFCSB-DT4S3-E	3PF PLUG TO DT4S,3.0M	3 METRE
3PFCSB-DT4S3.5-E	3PF PLUG TO DT4S,3.5M	3.5 METRE
3PFCSB-DT4S4-E	3PF PLUG TO DT4S,4.0M	4 METRE
3PFCSB-DT4S4.5-E	3PF PLUG TO DT4S,4.5M	4.5 METRE
3PFCSB-DT4S5-E	3PF PLUG TO DT4S,5.0M	5 METRE

7 Core and 2Core Cables with CSB to AMP Connectors **NEW**

Introducing our new Cables with Large Harness System Plug and AMP super seal connectors—engineered for durability and versatility. These water-resistant cables are fully compatible with the Large Harness Systems and adapt to AMP connectors seamlessly. They offer flexible solutions for a wide range of applications. Built tough for performance, these cables are ready to power your next project.



Part No.	Description	Length
7CF.5-4AMP	7CF PLUG TO 4AMP	50 CENTIMETRES



Part No.	Description	Length
2PF.25-2AMP	2PF PLUG TO 2AMP	25 CENTIMETRES
2PF.5-2AMP	2PF PLUG TO 2AMP	50 CENTIMETRES

Cables for Single Function Lamps

Many customers still prefer to use the recessed type rectangle or round lights for their trailer builds. The 7CFS series of plugs allows this to happen by splitting from the main cable a series of individual cables and plugs to suit 1) Stop/Tail Lamp 2) Indicator Lamp 3) Reverse Lamp.



Part No.	Cable Function	Length
7CFSTIRLB	LEFT SIDE MAIN CABLE CONNECTOR FOR STOP/TAIL/INDICATOR/REVERSE	140MM RED/BLACK 200MM YELLOW



Part No.	Cable Function	Length
7CFSTIRR	RIGHT SIDE MAIN CABLE CONNECTOR FOR STOP/TAIL/INDICATOR/REVERSE	140MM RED/BLACK 200MM GREEN



Part No.	Cable Function	Length
7CFSTILB	LEFT SIDE MAIN CABLE CONNECTOR FOR STOP/TAIL/INDICATOR	140MM RED 200MM YELLOW



Part No.	Cable Function	Length
7CFSTIRB	RIGHT SIDE MAIN CABLE CONNECTOR FOR STOP/TAIL/INDICATOR	140MM RED 200MM GREEN

Accessory Plugs for Individual Single Function Lamps

Colour coded depending on the function, the Accessory plugs allow other single-function recessed lamps that use the standard 3 Pin connectors to be used in the harness system.



Part No.	Cable Function	Length
3PFSTB	STOP/TAIL FUNCTION	200MM



Part No.	Cable Function	Length
2PFIB	REAR INDICATOR FUNCTION	200MM



Part No.	Cable Function	Length
2PFRB	REVERSE FUNCTION	200MM

Single Function Lamps with Plugin Cable Connector

Note: Visit our website, www.ledautolamps.com for further specifications and mounting information.

102 Series - SIZE 130MM ROUND X 12MM



20CM
CABLE
WITH
PLUG

Part No. 102RMCB
Function STOP/TAIL



20CM
CABLE
WITH
PLUG

Part No. 102AMCB
Function INDICATOR



20CM
CABLE
WITH
PLUG

Part No. 102WMCB
Function REVERSE

132 Series - SIZE 130MM X 86MM X 16MM



20CM
CABLE
WITH
PLUG

Part No. 132RMCB
Function STOP/TAIL



20CM
CABLE
WITH
PLUG

Part No. 132AMCB
Function INDICATOR



20CM
CABLE
WITH
PLUG

Part No. 132WMCB
Function REVERSE



Part No. 59401
Function GROMMET

Single Function Lamps Available for use with Accessory Plugs

113 Series - SIZE 109MM ROUND X 12MM



Part No. 113RMB
Function STOP/TAIL



Part No. 113AMB
Function INDICATOR



Part No. 113WMB
Function REVERSE



Part No. 53401
Function GROMMET

110 Series - SIZE 109MM ROUND X 12MM

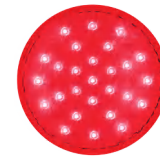

Part No. 110RMB
Function STOP/TAIL



Part No. 110AMB
Function INDICATOR

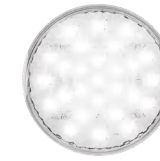

Part No. 110WMB
Function REVERSE



Part No. 53101
Function GROMMET

130 Series - SIZE 134MM X 86MM X 16MM



Part No. 130RMB
Function STOP/TAIL/
REFLECTOR



Part No. 130AMB
Function INDICATOR



Part No. 130WMB
Function REVERSE



Part No. 59401
Function GROMMET

134 Series - SIZE 134MM X 86MM X 16MM



Part No. 134RMB
Function STOP/TAIL/
REFLECTOR



Part No. 134AMB
Function INDICATOR/
REFLECTOR



Part No. 134WMB
Function REVERSE/
REFLECTOR



Part No. 59401
Function GROMMET

Lamps with DT6S or DT2S Connectors



NEW

Our compatible range of lighting products is designed to seamlessly integrate with our durable 2, 3, and 7 core cables that terminate with DT Deutsch connectors plugs. These water-resistant cables support reliable power delivery and compatibility with Large Harness Systems, ensuring dependable performance across various lighting applications and installation environments.



41 Series

SIZE 70MM X 42MM X 40MM

Part No	Function	Cable
41BLMDT	LICENCE LAMP	20CM WITH DT04-2P



7312 Series

SIZE 73MM X 73MM X 31MM

Part No	Function	Cable
7312BMDT	12 WATT REVERSE LAMP	20CM WITH DT2P



Multi-Frequency -

SIZE 71x102x41MM

Part No	Function	Cable
EA5200-DT2P	REVERSE ALARM	CABLE WITH DT2P



42 Series

SIZE 74MM X 38MM X 35MM

Part No	Function	Cable
42ARM-DT2P	AMBER/RED SIDE MARKER	20CM WITH DT2P PLUG
42RM-DT2P	REAR OUT-LINE	20CM WITH DT2P PLUG
42AM-DT2P	SIDE DIRECTION	20CM WITH DT2P PLUG
42WM-DT2P	FRONT OUT-LINE	20CM WITH DT2P PLUG



97 Series

SIZE 99MM X 47MM X 28MM

Part No	Function	Cable
97ARIM-DT4P-E	AMBER/RED SIDE MARKER/INDICATOR	40CM WITH DT4P PLUG



35 Series -

SIZE 58MM X 35MM X 21MM

Part No	Function	Cable
35ARM-DT2P	AMBER/RED SIDE MARKER	DT2P PLUG
35AM-DT2P	SIDE DIRECTION	DT2P PLUG



800 Series -

SIZE 103MM X 70MM X 52MM

Part No	Function	Cable
800ARIML-DT4P	AMBER/RED SIDE MARKER	LHS, DT4P PLUG
800ARIMR-DT4P	AMBER/RED SIDE MARKER	RHS, DT4P PLUG



144AMF Beacon

SIZE 144MM X 91MM

Part No	Function	Cable
144AMF-DT2P	AMBER STROBE BEACON	CABLE WITH DT2P



223 Series

SIZE 223MM X 96MM X 25MM

Part No	Function	Cable
223BARM-DT6P-E	STOP/TAIL/INDICATOR/REFLECTOR	20CM WITH DT6P



150 Series

Part No	Function	Cable
150ARM-DT6P	STOP/TAIL/INDICATOR/REFLECTOR	20CM WITH DT6P

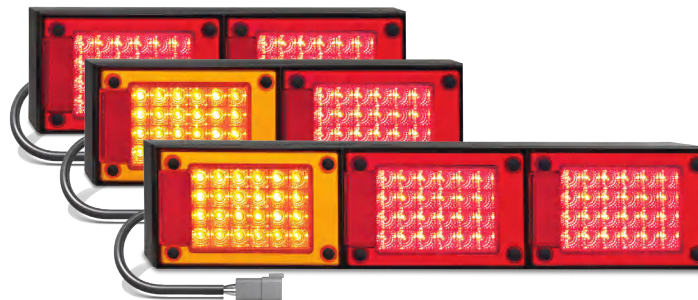

J3 Series -

SIZE 400MM OR 595MM X 130MM X 45MM

Part No	Side	Function	Cable
J2BARM-DT6P-E	L/R	STOP/TAIL/INDICATOR/REFLECTOR	20CM WITH DT6P
J2BRRM-DT6P	L/R	STOP/TAIL/REFLECTOR	20CM WITH DT6P
J3BARRM-DT6P-E	L/R	STOP/TAIL/INDICATOR/REFLECTOR	20CM WITH DT6P

Lamps with AMP Connectors



NEW

Our compatible range of lighting products is designed to seamlessly integrate with our durable 2, 3, and 7 core cables that terminate with DT Deutsch connectors plugs. These water-resistant cables support reliable power delivery and compatibility with Large Harness Systems, ensuring dependable performance across various lighting applications and installation environments.



41 Series

SIZE 70MM x 42MM x 40MM

Part No	Function	Cable
41BLM-2AMP	LICENCE LAMP	20CM WITH 2AMP PLUG



42 Series

SIZE 74MM x 38MM x 35MM

Part No	Function	Cable
42ARM-2AMP	AMBER/RED SIDE MARKER	20CM WITH 2AMP PLUG
42AM-2AMP	SIDE DIRECTION	20CM WITH 2AMP PLUG



128AMF Beacon

SIZE 130MM x 97MM

Part No	Function	Cable
128AMF-2AMP	AMBER STROBE BEACON	CABLE WITH 2AMP



J3 Series - SIZE 595MM x 130MM x 45MM

Part No	Function	Cable
J3BARRM-4AMP	STOP/TAIL/INDICATOR/REFLECTOR	20CM WITH 4AMP

Rear Combination Lamps

Note: Visit our website, www.ledautolamps.com for further specifications and mounting information.



200 Series - SIZE 200MM X 134MM X 28MM

Part No	Function	Side	Cable
200CCARRMLCSB	STOP/TAIL/INDICATOR	LEFT	20CM WITH PLUG
200CCARRMRCB	STOP/TAIL/INDICATOR	RIGHT	20CM WITH PLUG



223 Series - SIZE 223MM X 96MM X 25MM

Part No	Function	Side	Cable
223BARMMLCSB	STOP/TAIL/INDICATOR	LEFT	20CM WITH PLUG
223BARMRCB	STOP/TAIL/INDICATOR	RIGHT	20CM WITH PLUG



280 Series - SIZE 282MM X 95MM X 28MM

Part No	Function	Side	Cable
280ARRMLCSB	STOP/TAIL/INDICATOR/REFLECTOR	LEFT	20CM WITH PLUG
280ARRMRCB	STOP/TAIL/INDICATOR/REFLECTOR	RIGHT	20CM WITH PLUG
280ARWMLCSB	STOP/TAIL/INDICATOR/REVERSE/REFLECTOR	LEFT	20CM WITH PLUG
280ARWMRCB	STOP/TAIL/INDICATOR/REVERSE/REFLECTOR	RIGHT	20CM WITH PLUG



SEQUENTIAL INDICATOR
DIFFUSED TAIL

355 Series - SIZE 356MM X 86MM X 35MM

Part No	Function	Side	Cable
355BARWMLCSB	STOP/TAIL/IND/REV/REF - BLACK CHROME	LEFT	40CM WITH PLUG
355BARWMRCB	STOP/TAIL/IND/REV/REF - BLACK CHROME	RIGHT	40CM WITH PLUG
355ARWMLCSB	STOP/TAIL/IND/REV/REF - CHROME	LEFT	40CM WITH PLUG
355ARWMRCB	STOP/TAIL/IND/REV/REF - CHROME	RIGHT	40CM WITH PLUG

Rear Combination Lamps

Note: Visit our website, www.ledautolamps.com for further specifications and mounting information.



SEQUENTIAL INDICATOR
DIFFUSED TAIL

385 Series - SIZE 387MM X 105MM X 30.5MM

Part No	Function	Side	Cable
385ARWMLCSB	STOP/TAIL/INDICATOR/REV, DIFFUSED TAIL	LEFT	40CM WITH PLUG
385ARWMRCB	STOP/TAIL/INDICATOR/REV, DIFFUSED TAIL	RIGHT	40CM WITH PLUG



3851 Series - SIZE 387MM X 105MM X 30.5MM

Part No	Function	Side	Cable
3851ARWMLCSB	STOP/TAIL/INDICATOR/REVERSE/REFLECTOR	LEFT	40CM WITH PLUG
3851ARWMRCB	STOP/TAIL/INDICATOR/REVERSE/REFLECTOR	RIGHT	40CM WITH PLUG



DIFFUSED TAIL

3852 Series - SIZE 387MM X 105MM X 30.5MM

Part No	Function	Side	Cable
3852ARWMLCSB	STOP/TAIL/INDICATOR/REV, DIFFUSED TAIL	LEFT	40CM WITH PLUG
3852ARWMRCB	STOP/TAIL/INDICATOR/REV, DIFFUSED TAIL	RIGHT	40CM WITH PLUG

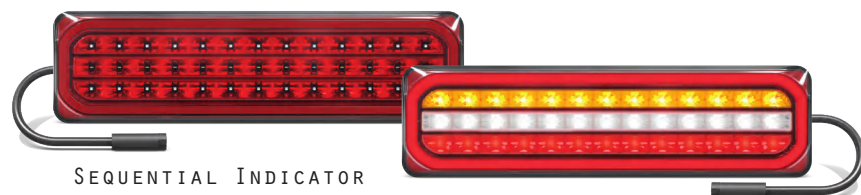

SEQUENTIAL INDICATOR
DIFFUSED TAIL

3853 Series - SIZE 387MM X 105MM X 30.5MM

Part No	Function	Side	Cable
3853ARWMLCSB	STOP/TAIL/INDICATOR/REV, DIFFUSED TAIL	LEFT	40CM WITH PLUG
3853ARWMRCB	STOP/TAIL/INDICATOR/REV, DIFFUSED TAIL	RIGHT	40CM WITH PLUG

Rear Combination Lamps

Note: Visit our website, www.ledautolamps.com for further specifications and mounting information.

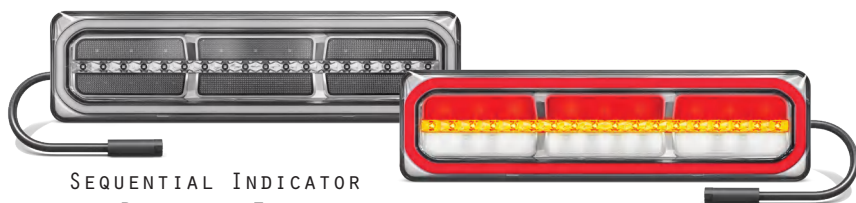

SEQUENTIAL INDICATOR
DIFFUSED TAIL

3854 Series - SIZE 387MM X 105MM X 30.5MM

Part No	Function	Side	Cable
3854ARWMLCSB	STOP/TAIL/INDICATOR/REV, RED DIFFUSED TAIL	LEFT	40CM WITH PLUG
3854ARWMRCSB	STOP/TAIL/INDICATOR/REV, RED DIFFUSED TAIL	RIGHT	40CM WITH PLUG
38541ARWMLCSB	STOP/TAIL/INDICATOR/REV, GREY DIFFUSED TAIL	LEFT	40CM WITH PLUG
38541ARWMRCSB	STOP/TAIL/INDICATOR/REV, GREY DIFFUSED TAIL	RIGHT	40CM WITH PLUG

3855 Series - SIZE 387MM X 105MM X 30.5MM

Part No	Function	Side	Cable
3855ARWMLCSB	STOP/TAIL/INDICATOR/REVERSE, DIFFUSED TAIL	LEFT	40CM WITH PLUG
3855ARWMRCSB	STOP/TAIL/INDICATOR/REVERSE, DIFFUSED TAIL	RIGHT	40CM WITH PLUG



DIFFUSED TAIL

460 Series - SIZE 460MM X 130MM X 33MM

Part No	Function	Side	Cable
460ARRMLCSB	STOP/TAIL/INDICATOR/REFLECTORS	LEFT	20CM WITH PLUG
460ARRMRCSB	STOP/TAIL/INDICATOR/REFLECTORS	RIGHT	20CM WITH PLUG
460ARWMLCSB	STOP/TAIL/INDICATOR/REVERSE/REFLECTORS	LEFT	20CM WITH PLUG
460ARWMRCSB	STOP/TAIL/INDICATOR/REVERSE/REFLECTORS	RIGHT	20CM WITH PLUG



520 Series - SIZE 520MM X 141MM X 28.5MM

Part No	Function	Side	Cable
520ARWMLCSB	STOP/TAIL/INDICATOR/REV, DIFFUSED TAIL	LEFT	40CM WITH PLUG
520ARWMRCSB	STOP/TAIL/INDICATOR/REV, DIFFUSED TAIL	RIGHT	40CM WITH PLUG

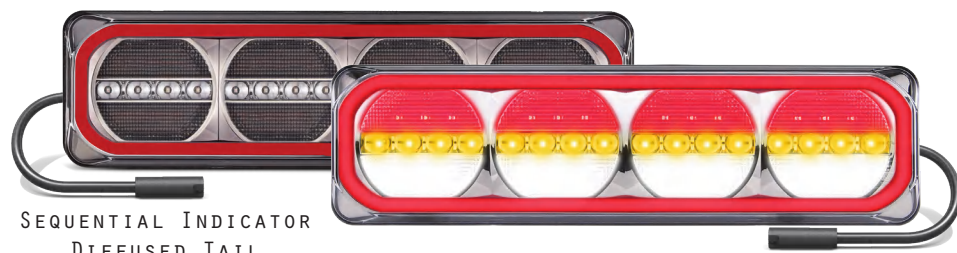

SEQUENTIAL INDICATOR
DIFFUSED TAIL

Rear Combination Lamps

Note: Visit our website, www.ledautolamps.com for further specifications and mounting information.

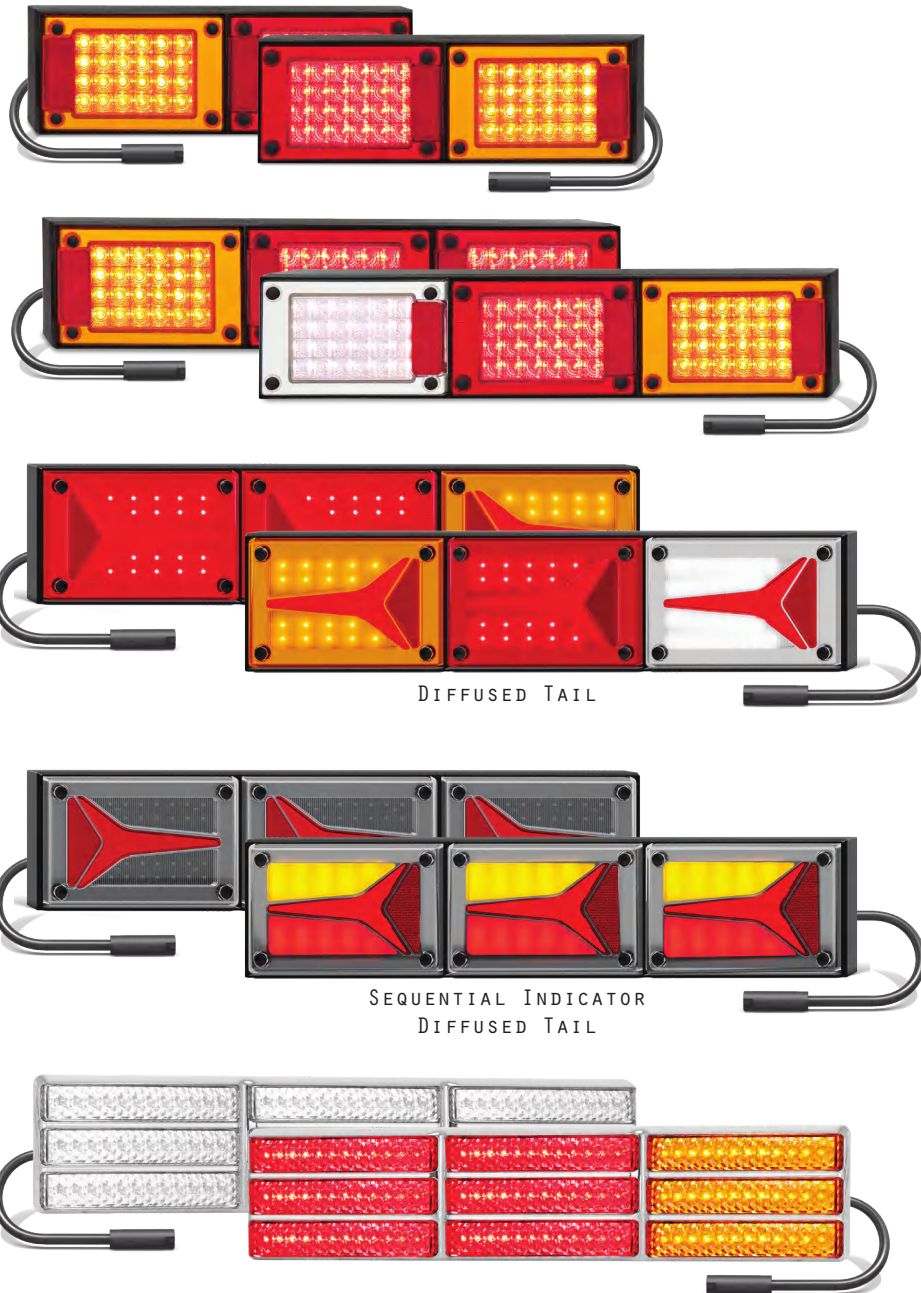

DIFFUSED TAIL

SEQUENTIAL INDICATOR
DIFFUSED TAIL

J3 Series - SIZE 400MM X 130MM X 45MM/595MM X 130MM X 45MM

Part No	Function	Side	Cable
J2BARM LCSB	STOP/TAIL/INDICATOR/REFLECTORS	LEFT	20CM WITH PLUG
J2BARM RCSB	STOP/TAIL/INDICATOR/REFLECTORS	RIGHT	20CM WITH PLUG
J3BARRM LCSB	STOP/TAIL/INDICATOR/REFLECTORS	LEFT	20CM WITH PLUG
J3BARRM RCSB	STOP/TAIL/INDICATOR/REFLECTORS	RIGHT	20CM WITH PLUG
J3BARWMLCSB	STOP/TAIL/INDICATOR/REVERSE/REFLECTORS	LEFT	20CM WITH PLUG
J3BARWMRCSB	STOP/TAIL/INDICATOR/REVERSE/REFLECTORS	RIGHT	20CM WITH PLUG

595 Series - SIZE 595MM X 130MM X 45MM

Part No	Function	Side	Cable
595BARRM LCSB	STOP/TAIL/INDICATOR/REFLECTORS	LEFT	40CM WITH PLUG
595BARRM RCSB	STOP/TAIL/INDICATOR/REFLECTORS	RIGHT	40CM WITH PLUG
595BARWMLCSB	STOP/TAIL/INDICATOR/REVERSE/REFLECTORS	LEFT	40CM WITH PLUG
595BARWMRCSB	STOP/TAIL/INDICATOR/REVERSE/REFLECTORS	RIGHT	40CM WITH PLUG

595 Series - SIZE 595MM X 130MM X 45MM

Part No	Function	Side	Cable
595STIM3 LCSB	STOP/TAIL/INDICATOR/REFLECTORS	LEFT	40CM WITH PLUG
595STIM3 RCSB	STOP/TAIL/INDICATOR/REFLECTORS	RIGHT	40CM WITH PLUG

J9 Series - SIZE 595MM X 130MM X 28MM

Part No	Function	Side	Cable
J9CCARRM LCSB	STOP/TAIL/INDICATOR	LEFT	20CM WITH PLUG
J9CCARRM RCSB	STOP/TAIL/INDICATOR	RIGHT	20CM WITH PLUG

97 Series Category 5 Side Direction Indicator/Marker Lamps

Note: Visit our website, www.ledautolamps.com for further specifications and mounting information.



Black/Chrome Bezel - SIZE 99MM X 47MM X 28MM

Part No	Function	Cable
97ARIMCSB	SIDE MARKER/ CAT5 SIDE DIRECTION INDICATOR, BLACK BEZEL	40CM WITH PLUG
97CARIMCSB	SIDE MARKER/ CAT5 SIDE DIRECTION INDICATOR, CHROME BEZEL	40CM WITH PLUG



Black/Chrome Bezel - SIZE 99MM X 47MM X 28MM

Part No	Function	Cable
97AIMCSB	SIDE MARKER/ CAT5 SIDE DIRECTION INDICATOR, BLACK BEZEL	40CM WITH PLUG
97CAIMCSB	SIDE MARKER/ CAT5 SIDE DIRECTION INDICATOR, CHROME BEZEL	40CM WITH PLUG



Black/Chrome Bezel - SIZE 99MM X 47MM X 28MM

Part No	Function	Cable
97RIMCSB	REAR END OUTLINE, SUPPLEMENTARY INDICATOR**, BLACK BEZEL	40CM WITH PLUG
97CRIMCSB	REAR END OUTLINE, SUPPLEMENTARY INDICATOR**, CHROME BEZEL	40CM WITH PLUG



Black/Chrome Bezel - SIZE 99MM X 47MM X 28MM

Part No	Function	Cable
97WIMCSB	FRONT END OUTLINE, SUPPLEMENTARY INDICATOR**, BLACK BEZEL	40CM WITH PLUG
97CWIMCSB	FRONT END OUTLINE, SUPPLEMENTARY INDICATOR**, CHROME BEZEL	40CM WITH PLUG



50 Series - SIZE 60MM X 39.5MM X 32MM

Part No	Function	Cable
50ARMCSB	AMBER/RED SIDE MARKER	20CM WITH PLUG NEW
50RMCSB	REAR END OUTLINE MARKER	20CM WITH PLUG NEW
50AMCSB	SIDE DIRECTION INDICATOR	20CM WITH PLUG NEW
50WMCSB	FRONT END OUTLINE MARKER	20CM WITH PLUG NEW



42 Series - SIZE 74MM X 38MM X 35MM

Part No	Function	Cable
42ARMCSB	AMBER/RED SIDE MARKER	20CM WITH PLUG
42ARMCSB3M	AMBER/RED SIDE MARKER	20CM WITH PLUG 3M TAPE MOUNT NEW
42RMCSB	REAR END OUTLINE MARKER	20CM WITH PLUG
42AMCSB	SIDE DIRECTION SIDE MARKER	20CM WITH PLUG
42AMCSB3M	SIDE DIRECTION SIDE MARKER	20CM WITH PLUG 3M TAPE MOUNT NEW
42WMCSB3M	FRONT END OUTLINE MARKER	20CM WITH PLUG 3M TAPE MOUNT NEW
42WMCSB	FRONT END OUTLINE MARKER	20CM WITH PLUG



5025 Series - SIZE 50MM X 25MM X 21MM

Part No	Function	Cable
5025ARMCSB	AMBER/RED SIDE MARKER	20CM WITH PLUG
5025RMCSB	REAR END OUTLINE MARKER	20CM WITH PLUG
5025AMCSB	SIDE DIRECTION SIDE MARKER	20CM WITH PLUG
5025WMCSB	FRONT END OUTLINE MARKER	20CM WITH PLUG

Note:
** Supplementary Front and Rear Indicator is Non-ADR, to be used in conjunction with existing lamps

Marker Lamps and Side Direction Indicator Lamps

Note: Visit our website, www.ledautolamps.com for further specifications and mounting information.



58 Series - SIZE 58MM X 35MM X 21MM

Part No	Function	Cable
58ARMCSB	AMBER/RED SIDE MARKER	20CM WITH PLUG
58RMCSB	REAR END OUTLINE MARKER	20CM WITH PLUG
58AMCSB	SIDE DIRECTION SIDE MARKER	20CM WITH PLUG
58WMCSB	FRONT END OUTLINE MARKER	20CM WITH PLUG



37 Series - SIZE 70MM X 35MM X 20MM

Part No	Function	Cable
37ARMCSB	AMBER/RED SIDE MARKER	20CM WITH PLUG
37RMCSB	REAR END OUTLINE MARKER	20CM WITH PLUG
37AMCSB	SIDE DIRECTION SIDE MARKER	20CM WITH PLUG
37WMCSB	FRONT END OUTLINE MARKER	20CM WITH PLUG

COMING SOON!



44 Series - SIZE 100MM X 44MM X 12MM NEW

Part No	Function	Cable
44ARMLCSB	AMBER/RED LEFT SIDE MARKER/REF	20CM WITH PLUG
44ARMRCSB	AMBER/RED RIGHT SIDE MARKER/REF	20CM WITH PLUG
44RMCSB	REAR END OUTLINE MARKER/REF	20CM WITH PLUG
44AMCSB	SIDE DIRECTION SIDE MARKER/REF	20CM WITH PLUG
44WMCSB	FRONT END OUTLINE MARKER/REF	20CM WITH PLUG



EU38 Series - SIZE 100MM X 38MM X 13MM

Part No	Function	Cable
EU38RMCSB	REAR END OUTLINE MARKER/REFLECTOR	20CM WITH PLUG
EU38AMCSB	SIDE MARKER/ REFLECTOR	20CM WITH PLUG
EU38WMCSB	FRONT END OUTLINE MARKER/REFLECTOR	20CM WITH PLUG



181 Series - SIZE 28MM ROUND X 5MM

Part No	Function	Cable
181RMCSB	REAR END OUTLINE MARKER	20CM WITH PLUG
181AMCSB	SIDE MARKER	20CM WITH PLUG
181WMCSB	FRONT END OUTLINE MARKER	20CM WITH PLUG

COMING SOON!



86 Series - SIZE 86MM X 31MM X 10MM NEW

Part No	Function	Cable
86ARMCSB	AMBER/RED SIDE MARKER	20CM WITH PLUG
86RMCSB	REAR END OUTLINE MARKER	20CM WITH PLUG
86AMCSB	SIDE DIRECTION SIDE MARKER	20CM WITH PLUG
86WMCSB	FRONT END OUTLINE MARKER	20CM WITH PLUG

Reverse Accessory Products

Important Note; When Reverse lamps are run as an accessory in the reverse system then the maximum power allowable is 60 watts in a 12 volt system or 120 watts in a 24 volt system. It is recommended the work lamps when used as a reverse light should be run from the blue wire/splitters, see page 27. The following table should be followed if Reverse Lamps are already used in the system and more are to be added.

Additional Reverse Lamps Max Combined Output in Watts

No. Of Reverse Lamps	12 Volt System	24 Volt System
2	46 Watts	92 Watts
4	36 Watts	72 Watts
6	24 Watts	48 Watts



7312 Series - SIZE 73MM X 73MM X 31MM

Part No	Function	Cable
7312BMCSB	12 WATT REVERSE LAMP	20CM WITH PLUG



7512 Series - SIZE 75MM X 75MM X 30MM

Part No	Function	Cable
7512BMCSB	12 WATT REVERSE LAMP	20CM WITH PLUG



Beepers - SIZE 100MM X 68MM X 41MM

Part No	Function	Cable
2PF200ETB	REVERSE BEEPER	20CM WITH PLUG
2PF200RAB	REVERSE BEEPER (DG)	20CM WITH PLUG



Squawkers - SIZE 100x68x41MM

Part No	Function	Cable
2PF200SQB	REVERSE SQUAWKER	20CM WITH PLUG

Licence Plate Lamps



35 Series

SIZE 76MM X 42MM X 30MM

Part No	Cable
35BLMCSB	20CM WITH PLUG
35CLMCSB	20CM WITH PLUG



6434 Series

SIZE 65MM X 30MM X 24MM

Part No	Cable
6434CWMCSB	15CM WITH PLUG
6434BWMCSB	15CM WITH PLUG



60 Series

SIZE 60MM X 22MM X 22MM

Part No	Cable
60BLMCSB	20CM WITH PLUG



41 Series

SIZE 70MM X 42MM X 40MM

Part No	Cable
41BLMCSB	20CM WITH PLUG

Rotating Beacon Accessory



LRB130 Beacon

SIZE 130MM X 53MM

Part No	Cable
LRB130CSB	13CM WITH PLUG

USED WITH BLUE ACCESSORY WIRE SEE PAGE 27

7 Core Main Plugs and Covers

The 7CJB rear junction splitters are designed to split the 7 Core cable into a left and right side for rear lighting functions of Stop/Tail, Indicator and Reverse. The 7CJB also has left and right side 2 pin plugs to connect licence plate and marker lamps. The 7P3WB is a 7 Core cable splitter which gives you the ability to add another rear combination lamp and continue the harness cable before terminating with a final rear combination lamp assembly. The covers available for the plugs have been created for extra strength and engineered to a breaking strain of 25 kg. The connection cover is for secure fitment and completes Dangerous Goods Rating AS2809.



Part No. Size
7CJB | 89MM x 61MM



Part No. Size
CCJB | 186MM x 116MM



Part No. Size
7P3WB | 94MM x 44MM



Part No. Size
7PCB | 193MM x 50MM

7 Core Junction Splitter and Cover

The 7CJEB 7 Core Rear Junction Splitter Extension is used with the 7CJB, above to connect a 7 pin trailer base at the rear of the trailer. Its purpose is to connect another trailer to the existing harness system when using the 7CFTB rear trailer plug.



Part No. Size
CMEB | 188MM x 178MM



Part No. Size
7CJEB | 200MM

7 Core Trailer Base Front/Rear Termination

Heavy Duty, EBS, and 24 Volt Sockets available, see Page 28-29 for more information.



FRONT OF TRAILER

Part No. Size
B730MTB | 500MM WITH PLUG
12 VOLT



FRONT OF TRAILER

Part No. Size
7CMTB | 200MM WITH PLUG
12 VOLT



REAR OF TRAILER

Part No. Size
7CFTB | 200MM WITH PLUG
24 VOLT

Marker Lamp Splitters

Defined by its brown colour, the Marker lamp splitters split from the 7 Core cable and power the marker lamps. The 7CMFB has dual splitters at a right angle to the 7 Core cable. The 7CFFB also has dual splitters but runs parallel to the 7 Core cable. The 7CFB is a single splitter that runs parallel to the 7 Core cable. The covers for the plugs have been created for extra strength and engineered to a breaking strain of 25kg. The connection cover is for secure fitment and completes Dangerous Goods Rating AS2809.



DUAL MARKER LAMP SPLITTER

Part No. Size
7CMFB | 78MM x 60MM



DUAL MARKER LAMP SPLITTER

Part No. Size
7CFFB | 78MM x 37MM



MARKER LAMP SPLITTER

Part No. Size
7CFB | 78MM x 37MM



SPLITTER COVER

Part No. Size
CMAB | 175MM x 128MM



SPLITTER COVER

Part No. Size
CMMB | 177MM x 44MM



SPLITTER COVER

Part No. Size
CMBB | 177MM x 44MM

2 Core Splitters

The 2 Core splitters are used to split the 2 Core cable and powers Marker Lamps, Indicator (2 Core) lamps, Reverse lamps and Accessories. The plugs we have designed are 100% water-resistant, with a sealing lip that will not allow water ingress. The cover for the plugs have been created for extra strength and engineered to a breaking strain of 15kg. The connection covers ensures a secure fitment and completes Dangerous Goods Rating AS2809.



2 CORE/3 WAY SPLITTER

Part No. Size
2P3WB | 62MM x 28MM



2 CORE/4 WAY SPLITTER

Part No. Size
2P4WB | 62MM x 28MM



2P3WB SPLITTER COVER

Part No. Size
2P3CB | 125MM x 35MM

Indicator Lamp Splitters

Defined by its Yellow colour, the Indicator lamp splitters split from the 7 Core cable and power both the left and right-hand side indicator lamps. The 7CMIB has dual splitters at a right angle to the 7 Core cable. The 7CIRLB also has dual splitters but runs parallel to the 7 Core cable. The 7CILB and the 7CIRB are single splitters parallel with the 7 Core cable used for left-hand and right-hand indicators and defined by their colours Yellow for left and Green for right. The covers for the plugs have been created for extra strength and engineered to a breaking strain of 25kg. The connection cover is for secure fitment and completes Dangerous Goods Rating AS2809.



LEFT & RIGHT INDICATOR

Part No. Size
7CMIB | 78MM x 60MM



LEFT & RIGHT INDICATOR

Part No. Size
7CIRLB | 78MM x 37MM

LEFT INDICATOR

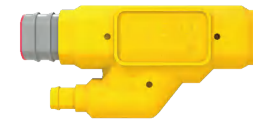

Part No. Size
7CILB | 78MM x 37MM

RIGHT INDICATOR



Part No. Size
7CIRB | 78MM x 37MM



Part No. Size
CMAB | 175MM x 128MM



Part No. Size
CMMB | 177MM x 44MM



Part No. Size
CMBB | 177MM x 44MM

Dual Function Marker/Indicator Splitters

Defined by its Yellow colour, the Dual function Marker/Indicator lamp splitter split from the 7 Core cable and power both the left and right-hand side Indicator/Marker lamps. The 7CILR3B has dual splitters at a right angle to the 7 Core cable. The 3P3IMB is a plug that splits one cable into two, and this allows the fitter to add as many combination Indicator/Marker lamps as required. All connectors have covers available for secure fitment of the cables ensuring Dangerous Goods Rating AS2809.



COMBINATION LEFT & RIGHT INDICATOR

Part No. Size
7CILR3B | 78MM x 37MM



Part No. Size
CMMB | 177MM x 44MM



3 CORE/3 WAY INDICATOR SPLITTER

Part No. Size
3P3IMB | 62MM x 28MM



Part No. Size
2P3CB | 125MM x 35MM

Reverse Lamp Splitters

Defined by its black colour, the Reverse lamp splitters split from the 7 Core cable and power the reverse lamps and reverse beeper. The 7CRRB has dual splitters that run parallel to the 7 Core cable. The 7CRB is a single splitter that runs parallel to the 7 Core cable. The 2P3WB is a plug that splits one cable into two, allowing the fitter to add additional Reverse lamps. The cover for the plugs, created are engineered for extra strength to a breaking strain of 15kg for 2 Core and 25kg for 7 Core. The connection cover is for secure fitment and completes Dangerous Goods Rating AS2809.



DUAL REVERSE LAMP SPLITTER

Part No. 7CRRB **Size** 78MM x 37MM



REVERSE LAMP SPLITTER

Part No. 7CRB **Size** 78MM x 37MM



2 CORE/3 WAY SPLITTER

Part No. 2P3WB **Size** 62MM x 28MM



Part No. CMMB **Size** 177MM x 44MM



Part No. CMBB **Size** 177MM x 44MM



Part No. 2P3CB **Size** 125MM x 35MM

Separate Stop/Tail Lamp Compatible with 3 Core Stop/Tail Plugs and Cables

The heavy-duty truck harness system has provisions for a separate stop/tail lamp. Plug in the stop/tail adapter, plug 7CSTB into the harness system, then run a 3 Core (3PMF) cable to connect a stop/tail lamp. If you require a second stop/tail lamp, then add the 3 Core splitter 3P3WB for an extra cable to connect the lamp. All connectors have covers available, ensuring Dangerous Goods Rating AS2809 and secure fitment with a breaking strain of 15kg for the cables.



BRAKE CONTROL LAMP SPLITTER

Part No. 7CSTB **Size** 78MM x 37MM



Part No. CMMB **Size** 177MM x 44MM



3 CORE/3 WAY SPLITTER

Part No. 3P3WB **Size** 62MM x 28MM



Part No. 2P3CB **Size** 125MM x 35MM

Brake Control or Accessory Splitter

Defined by its blue colour the 7CMBB has dual splitters at right angle to the 7 Core cable. The 7CBBB has dual splitters that run parallel with the 7 Core cable. The 7CBB plug is a single splitter that runs parallel with the 7 Core cable. These splitters power the brake control or any accessory when brake control is not required. The covers for the plugs have been created for extra strength and engineered to a breaking strain of 25kg. The connection cover is for secure fitment and completes Dangerous Goods Rating AS2809.

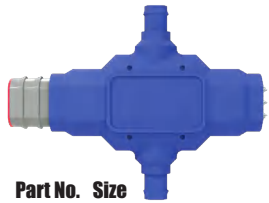

DUAL BRAKE CONTROL OR ACCESSORY LAMP SPLITTER

Part No. Size
7CMBB | 78MM X 60MM



DUAL BRAKE CONTROL OR ACCESSORY LAMP SPLITTER

Part No. Size
7CBBB | 78MM X 37MM



BRAKE CONTROL OR ACCESSORY LAMP SPLITTER

Part No. Size
7CBB | 78MM X 37MM



Part No. Size
CMAB | 175MM X 128MM



Part No. Size
CMBB | 177MM X 44MM



Part No. Size
CMBB | 177MM X 44MM

Main Cable 7 Core Splitters

All assembly plugs are colour coded to its specific function. Example - The Brown plug is for Marker Lamps. When requiring a marker lamp, add a brown plug in the harness line. The Yellow (LHS) or Green (RHS) plug is for Side Direction Indicator Lamps. When requiring a Side Direction Indicator lamp, add a yellow or green plug whether left or right hand side in the harness line.

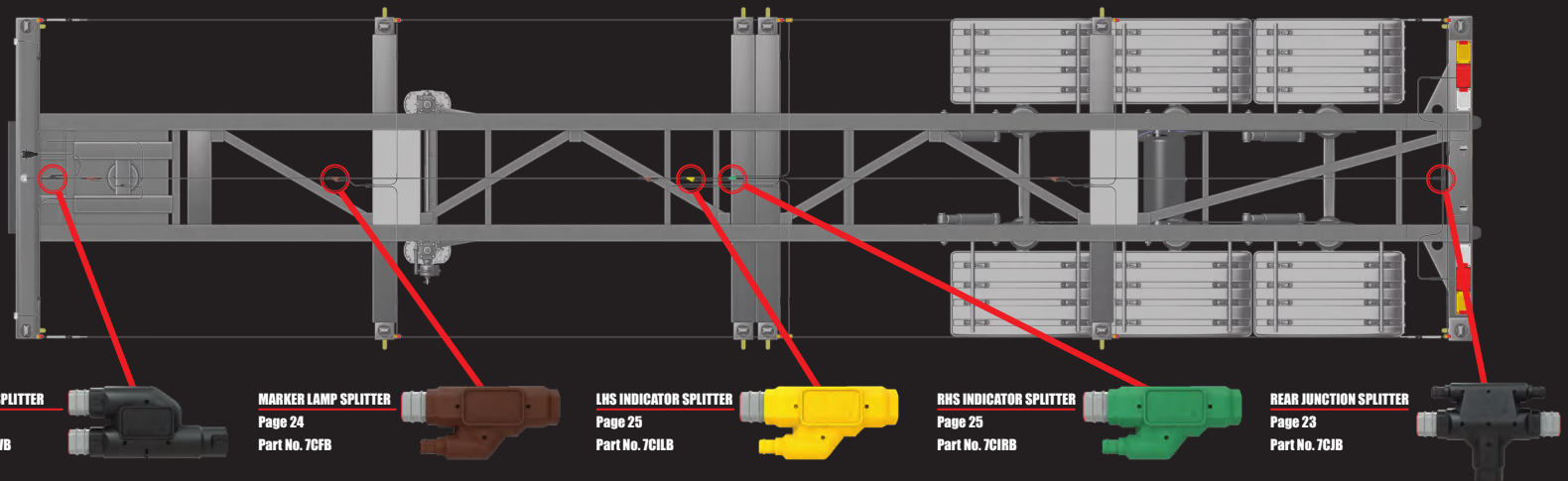

MAIN CABLE SPLITTER
Page 23
Part No. 7P3WB

MARKER LAMP SPLITTER
Page 24
Part No. 7CFB

LHS INDICATOR SPLITTER
Page 25
Part No. 7CILB

RHS INDICATOR SPLITTER
Page 25
Part No. 7CIRB

REAR JUNCTION SPLITTER
Page 23
Part No. 7CIB

Standard/Heavy Duty Sockets, Plugs and Suzi Coils

These 7 pin connectors and Suzi coils are for electrical connection between a vehicle and a trailer. Both voltages available, 12V - ISO 1724 and 24V - ISO 1185/DIN 72579. The plugs and connectors either use corrosion-resistant aluminium or plastic materials with Nickel-plated Brass contacts.



Part No. 7PSOCKETSDB
Description 7 PIN ALLOY STANDARD DUTY SOCKET, 12 VOLT

Part No. 7PSOCKETSDSB
Description 7 PIN ALLOY STANDARD DUTY SOCKET, 12 VOLT, SEALED

NEW



Part No. 7PPLUGSDB
Description 7 PIN ALLOY STANDARD DUTY PLUG, 12 VOLT

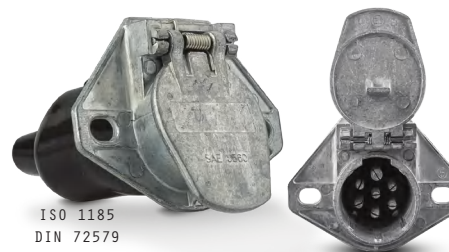

Part No. 7PSOCKETHD24B
Description 7 PIN ALLOY HEAVY DUTY SOCKET, 24 VOLT



Part No. 7PPLUGHD24B
Description 7 PIN ALLOY HEAVY DUTY PLUG, 24 VOLT

Part No. 7PSUZI1212
Description 7 PIN SUZI COIL, 60MM COIL DIAMETER, SHORT TAIL ENDS, TOTAL EXTENDED LENGTH 4.5M, 12 VOLT.



Part No. 7PSUZI1M1212
Description 7 PIN SUZI COIL, 60MM COIL DIAMETER, 1M LONG TAIL END, TOTAL EXTENDED LENGTH 5.6M, 12 VOLT.



Part No. 7PSUZI1224
Description 7 PIN SUZI COIL, 60MM COIL DIAMETER, SHORT TAIL ENDS, TOTAL EXTENDED LENGTH 4.5M, 12-24 VOLT.



Part No. 7PSUZI1M1224
Description 7 PIN SUZI COIL, 60MM COIL DIAMETER, 1M LONG TAIL END, TOTAL EXTENDED LENGTH 5.6M, 12-24 VOLT.



Part No. 7PSUZI2424
Description 7 PIN SUZI COIL, 60MM COIL DIAMETER, SHORT TAIL ENDS, TOTAL EXTENDED LENGTH 4.5M, 24 VOLT.



Part No. 7PSUZI1M2424
Description 7 PIN SUZI COIL, 60MM COIL DIAMETER, 1M LONG TAIL END, TOTAL EXTENDED LENGTH 5.6M, 24 VOLT.



ABS/EBS Sockets, Plugs and Suzi Coils

These connectors are specific for the ABS/EBS braking system between a truck, trailer or semitrailer, both for 12V and 24V systems. The ABS/EBS plugs, connectors conform to ISO/DIN 7638, and the materials used conform to ADR/GGVS norm requirements for vehicles transporting hazardous goods. The plugs are connected to the sockets with a steel bracket to avoid accidental disconnection. Mechanical resistance and water tightness guarantee an efficient and reliable electrical connection.

ABS/EBS
ISO/DIN 7638



Part No. 7PSOCKETEBS24B
Description 7 PIN EBS SOCKET, 24 VOLT

ABS/EBS
ISO/DIN 7638

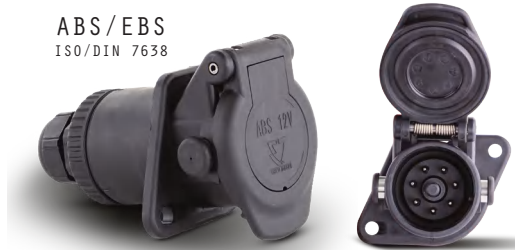

Part No. 7PSOCKETEBS12B
Description 7 PIN EBS SOCKET, 12 VOLT

ABS/EBS
ISO/DIN 7638



Part No. 7PPLUGESMB
Description 7 PIN EBS PLUG, 12/24V

ABS/EBS
ISO/DIN 7638



Part No. 7PSUZIEBSMB
Description 7 PIN SUZI COIL CONNECTORS WITH 300MM EXTENDED LENGTH FROM SUZI COIL ON EACH SIDE TOTAL EXTENDED LENGTH 4.5M, 12/24 VOLT

ABS/EBS
ISO/DIN 7638



Part No. 7PSUZIEBSM1B
Description 7 PIN SUZI COIL CONNECTORS WITH 300MM AND 1M EXTENDED LENGTH FROM SUZI COIL. TOTAL EXTENDED LENGTH 5.6M, 12/24 VOLT

Standard Type Skel or Flat Top Trailer



SKEL TRAILER
SCHEMATIC

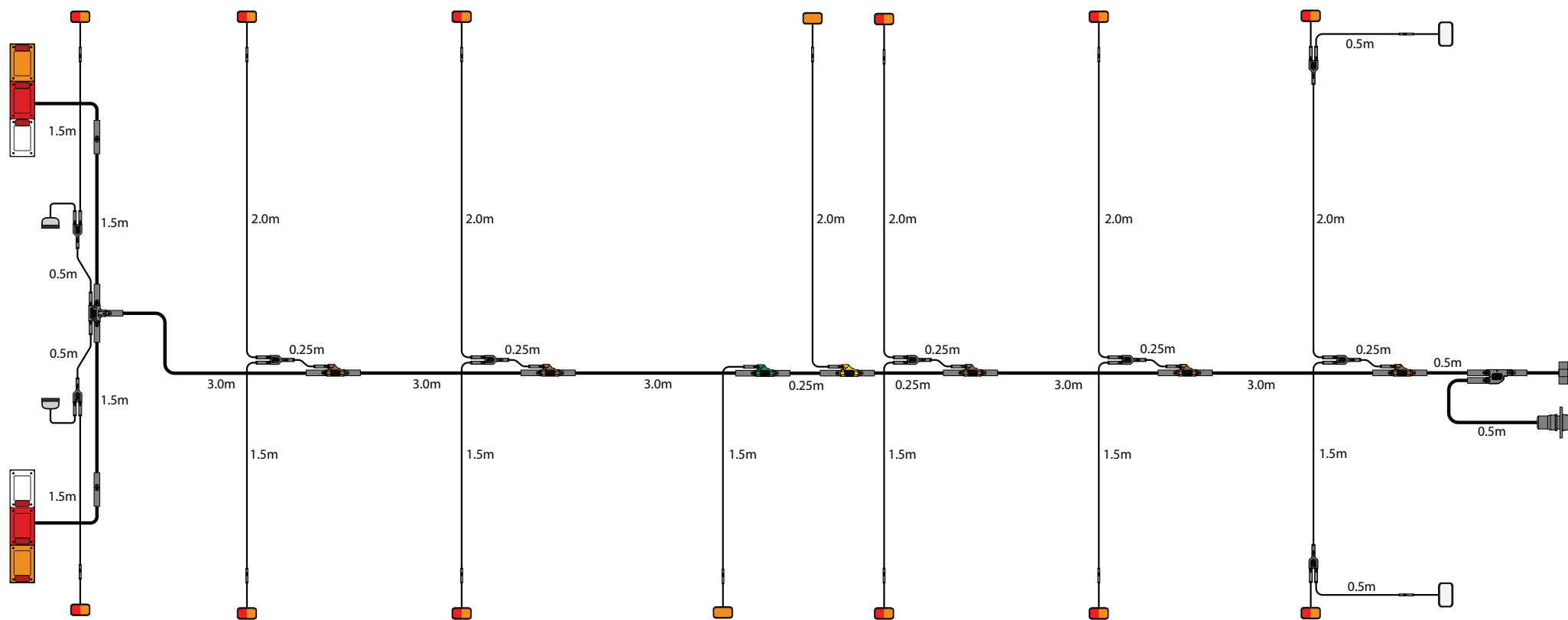

FLAT BED
SCHEMATIC

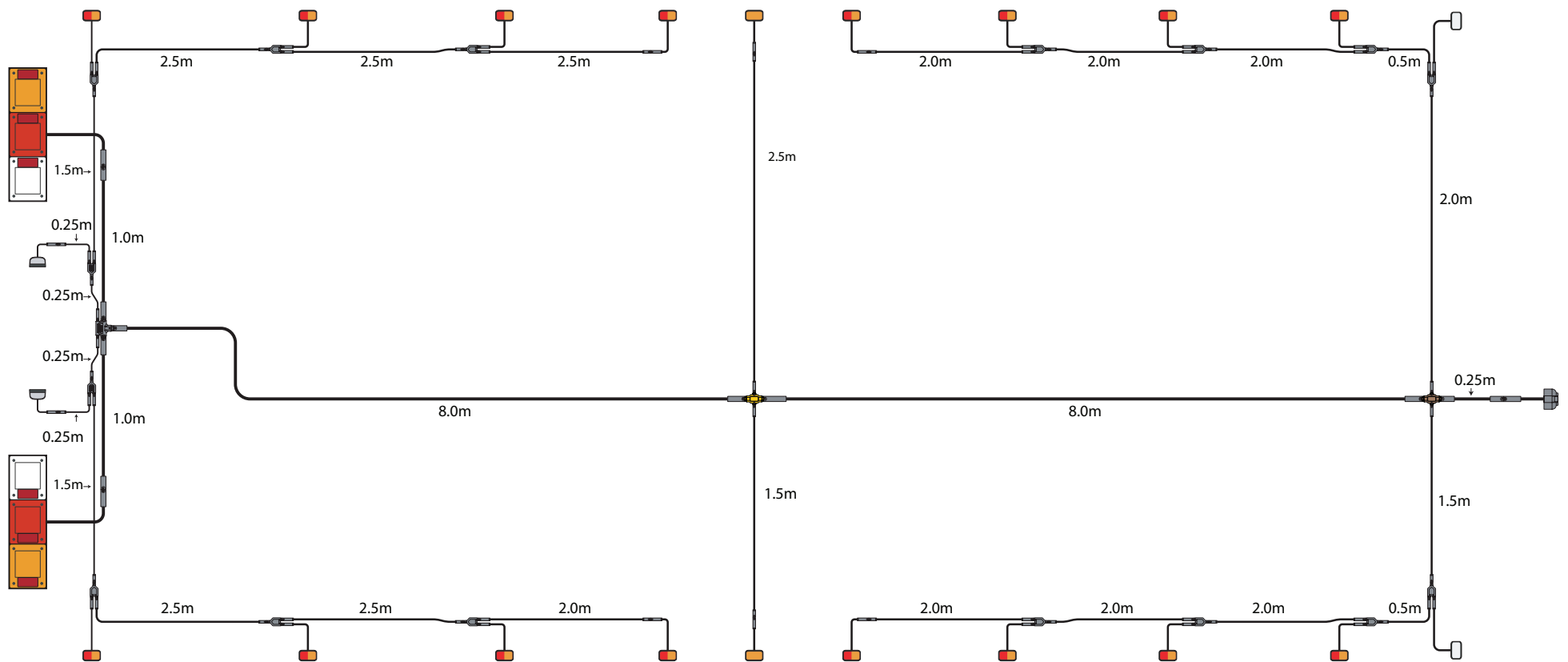

Refrigerator Trailer Semi, A Lead, Box

REFRIGERATOR SEMI
SCHEMATIC

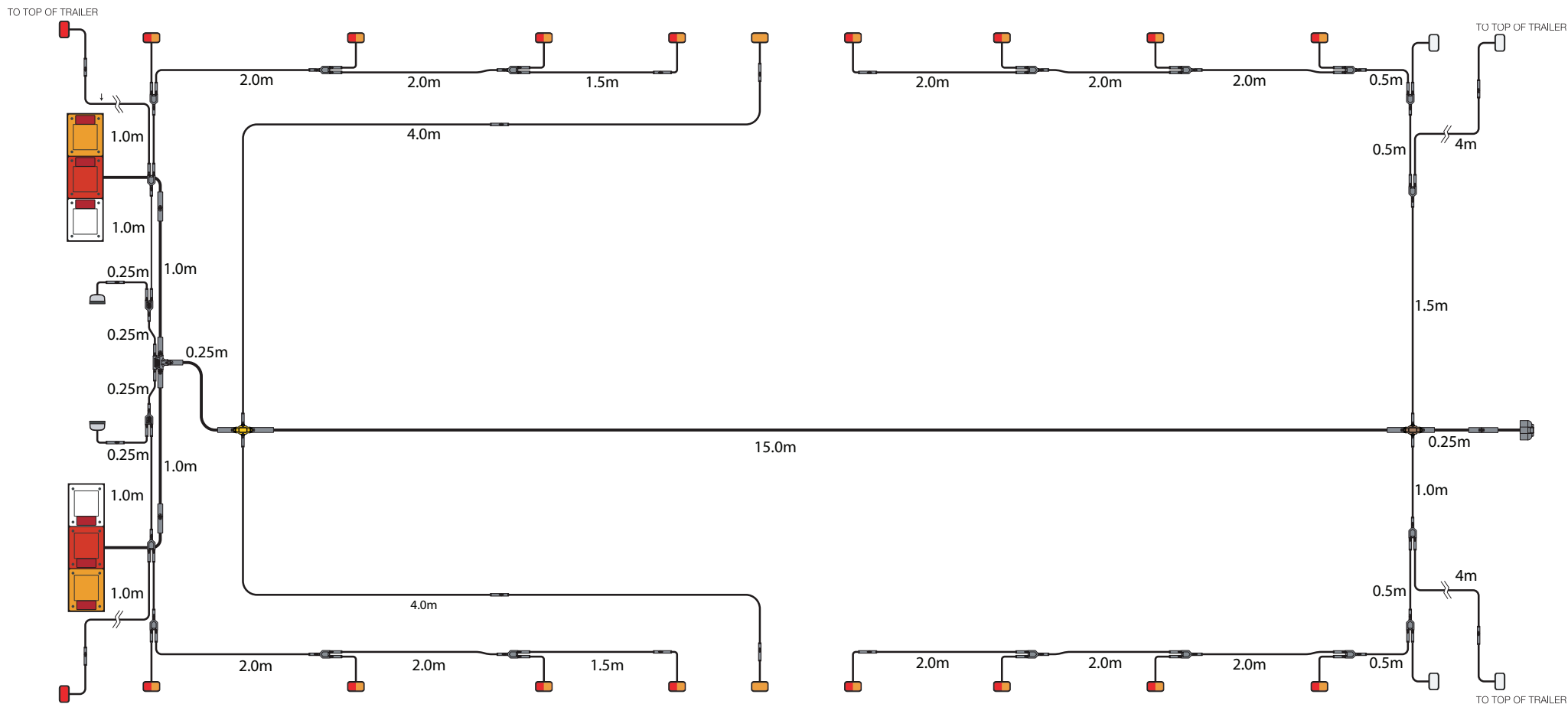

A-LEAD TRAILER
SCHEMATIC

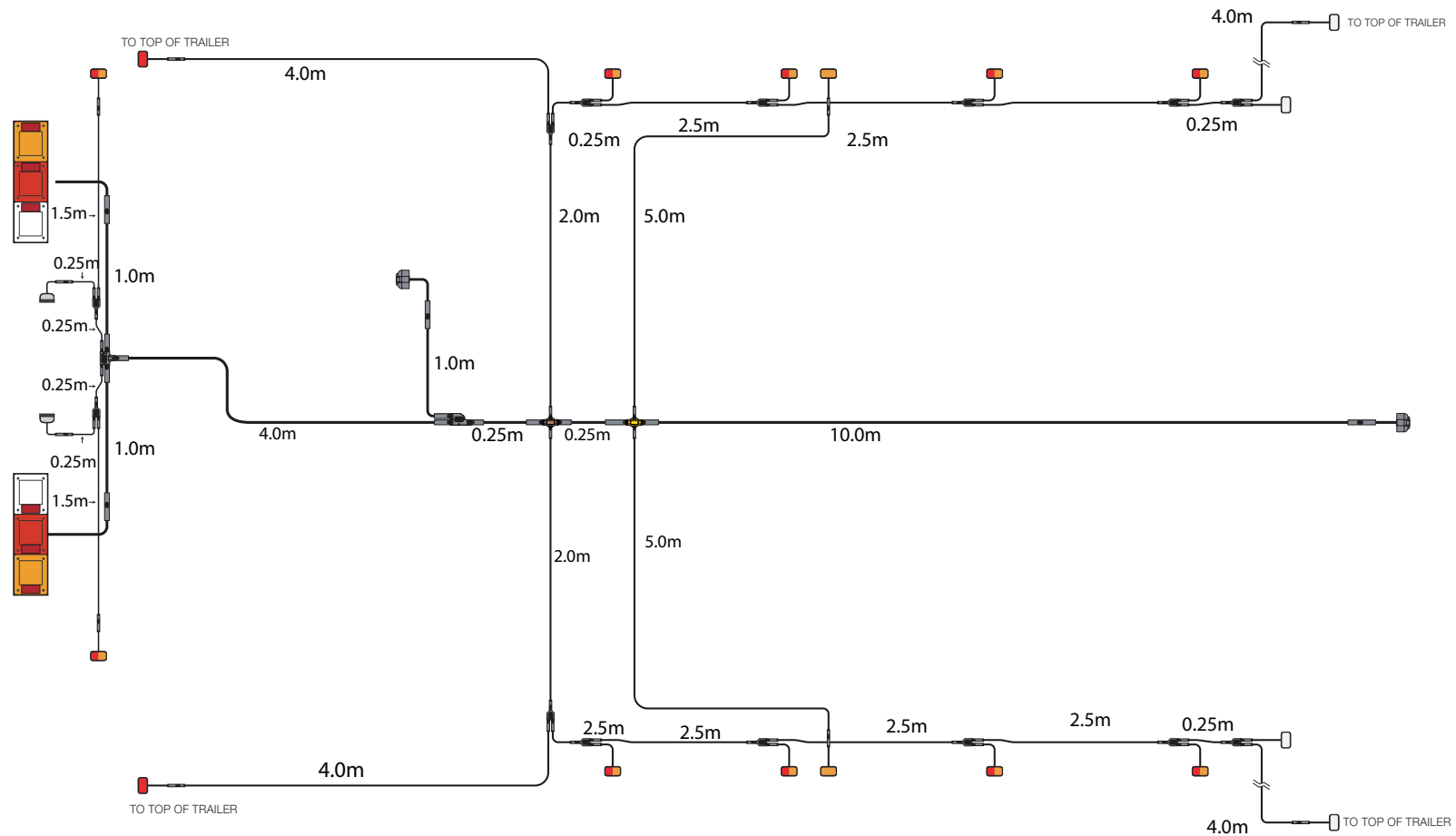

Curtainsider

CURTAINSIDER
SEMI SCHEMATIC

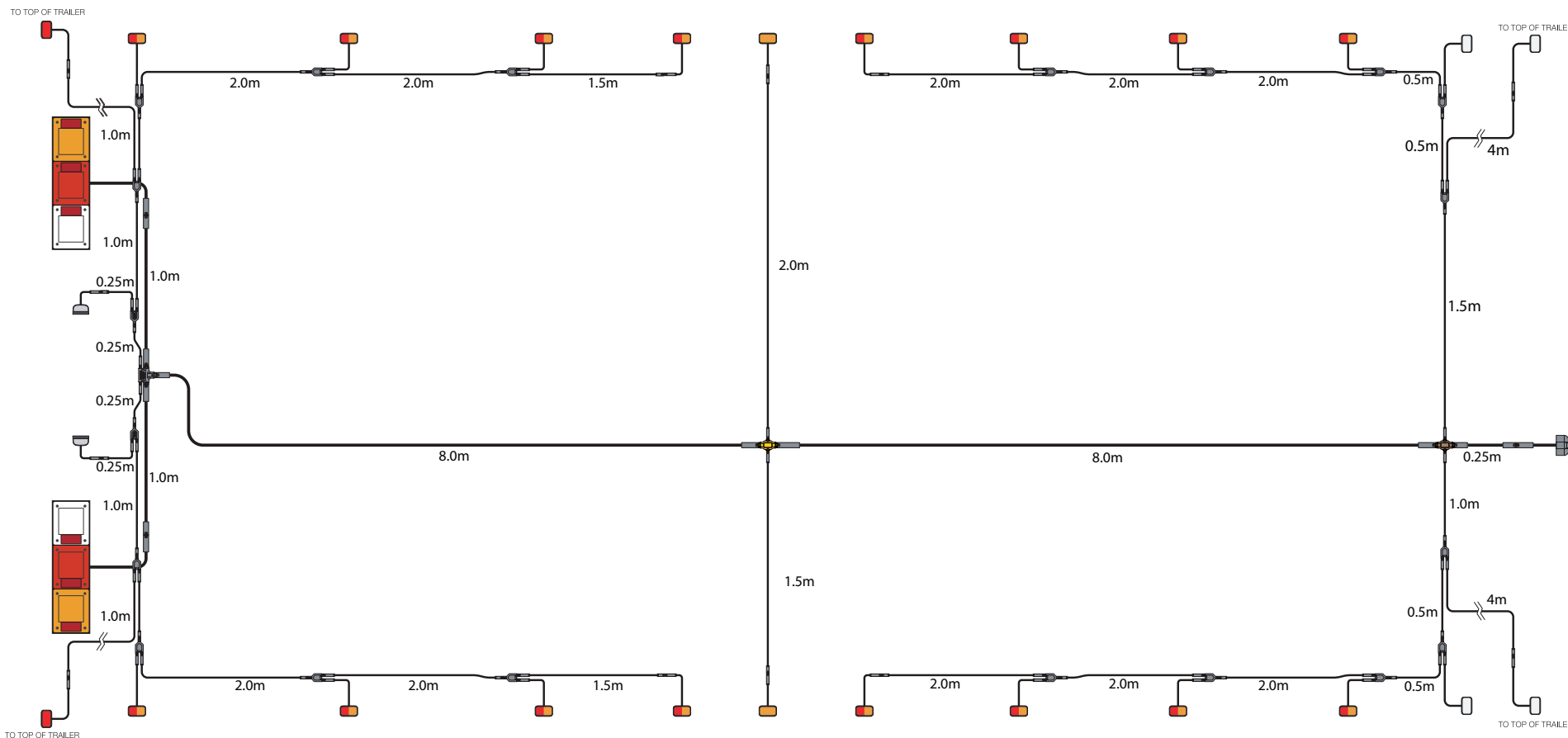

Curtainsider with Dual Function Marker/Indicator

CURTAINSIDER SEMI SCHEMATIC

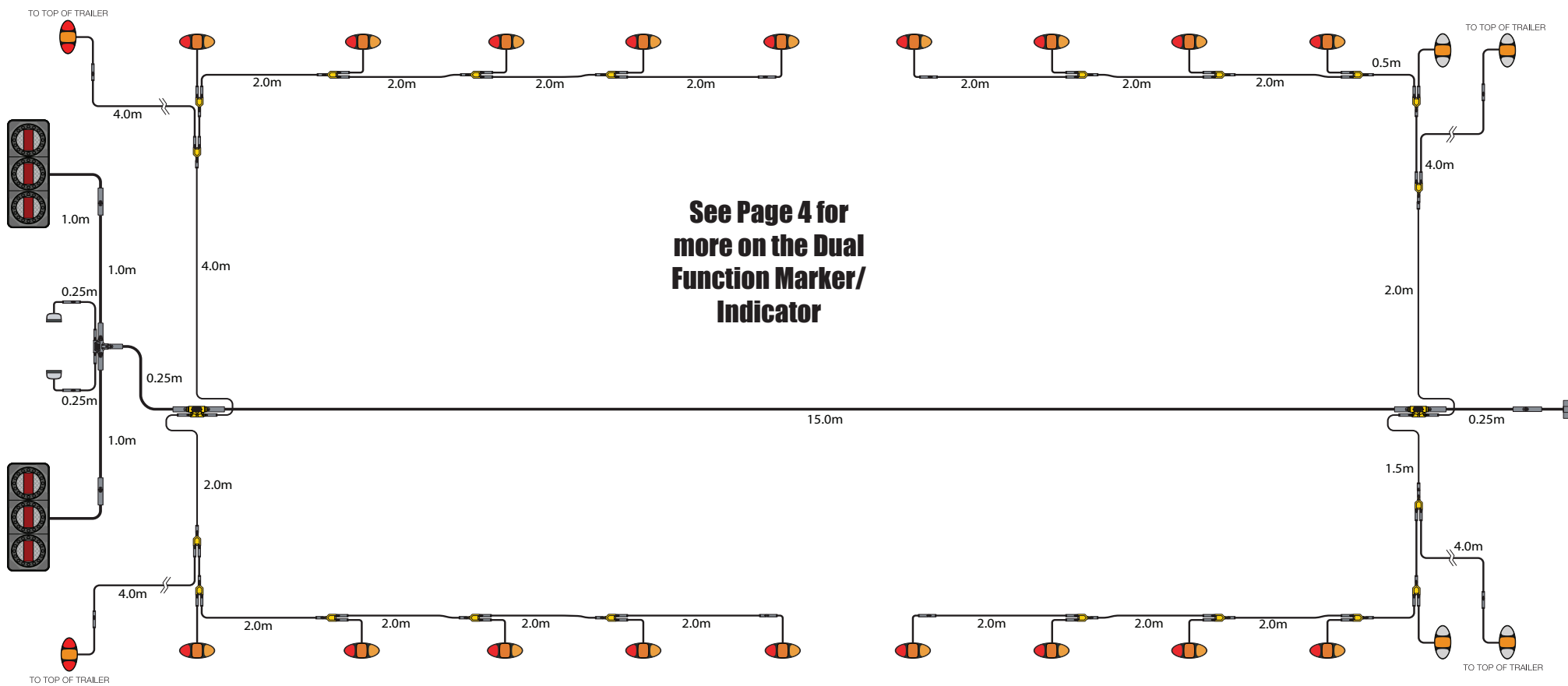

See Page 4 for more on the Dual Function Marker/Indicator

CURTAINSIDER
RIGID
SCHEMATIC

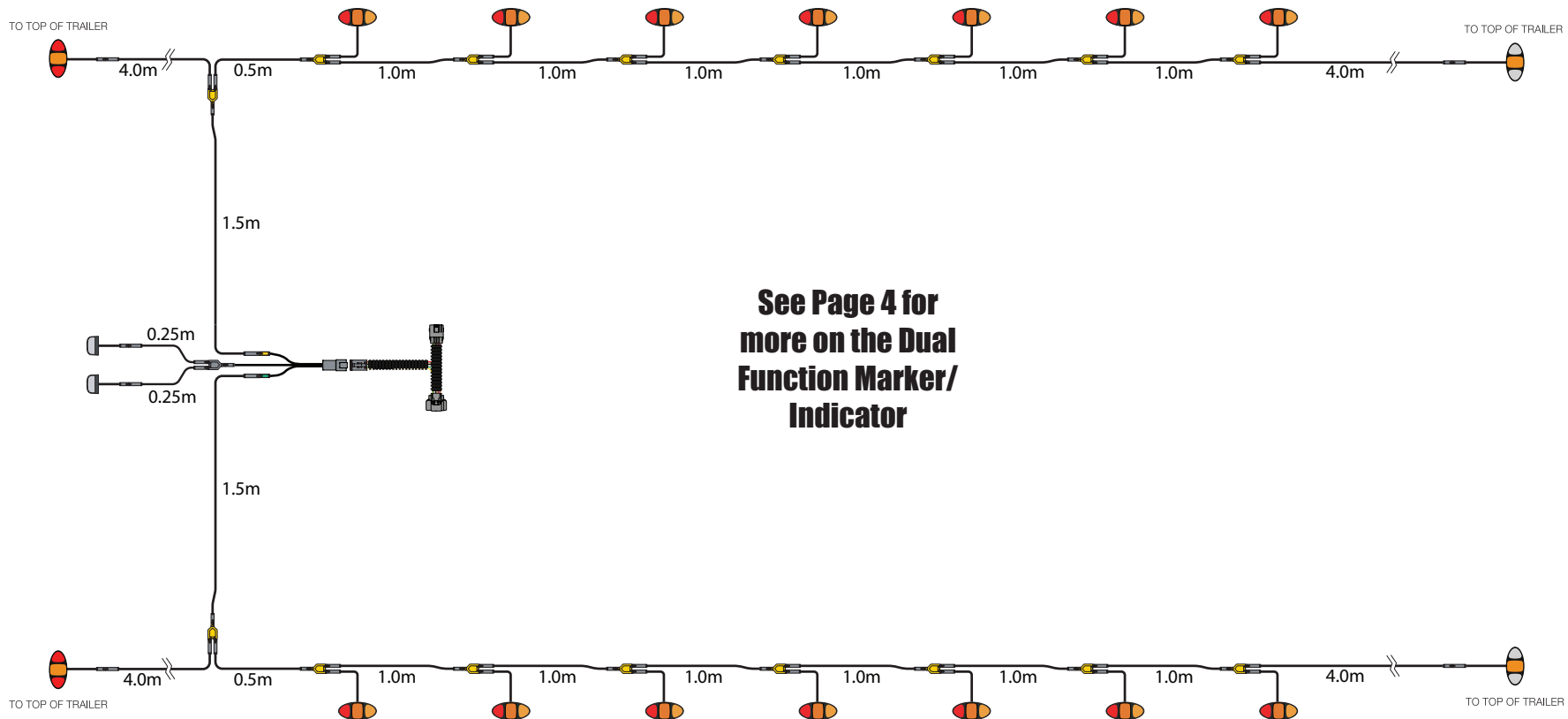

**See Page 4 for
more on the Dual
Function Marker/
Indicator**

A&B Coupling Dolly/Tag



LEAD/MIDDLE
CURTAINSIDER

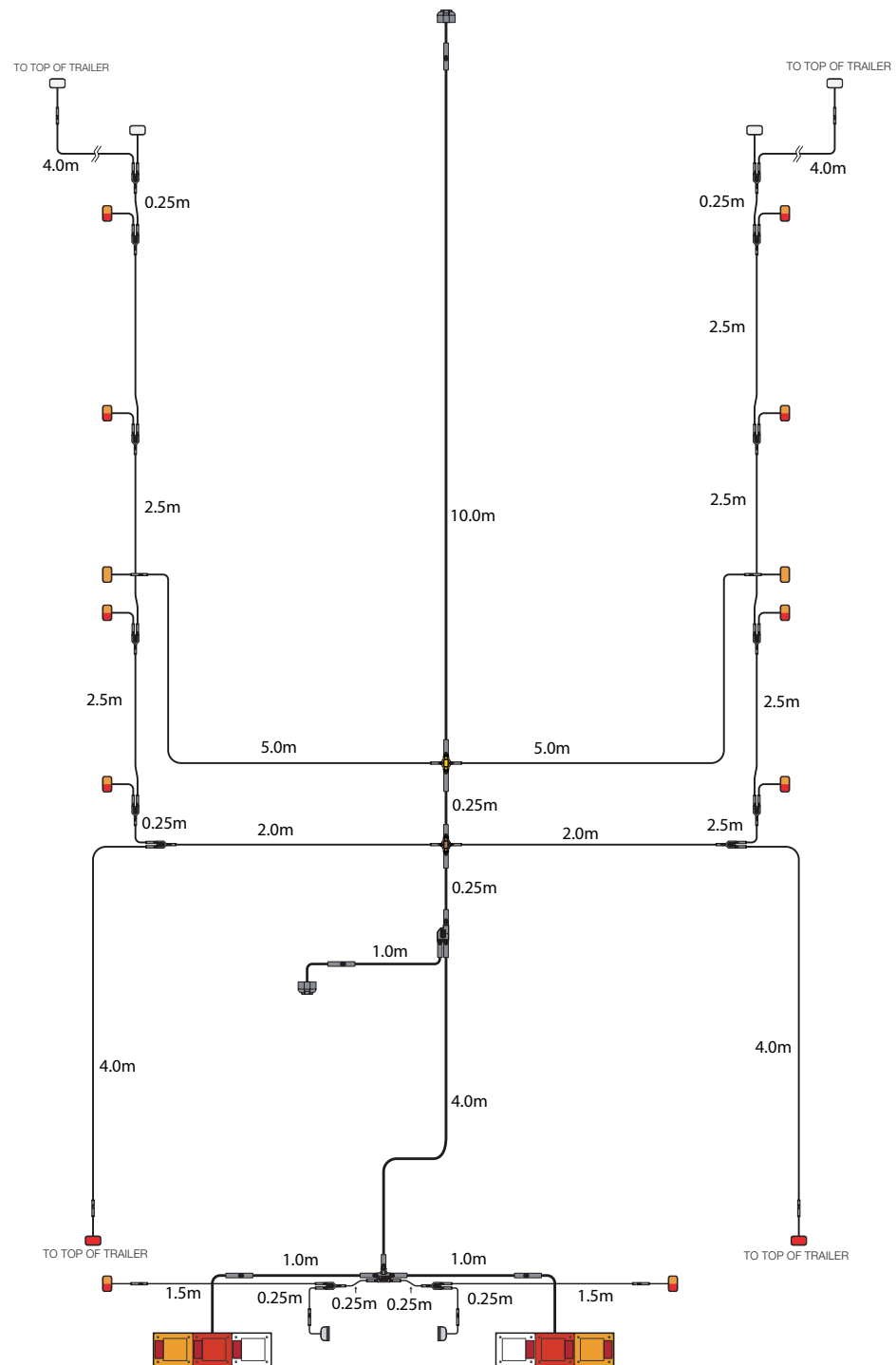



DOLLY SCHEMATIC

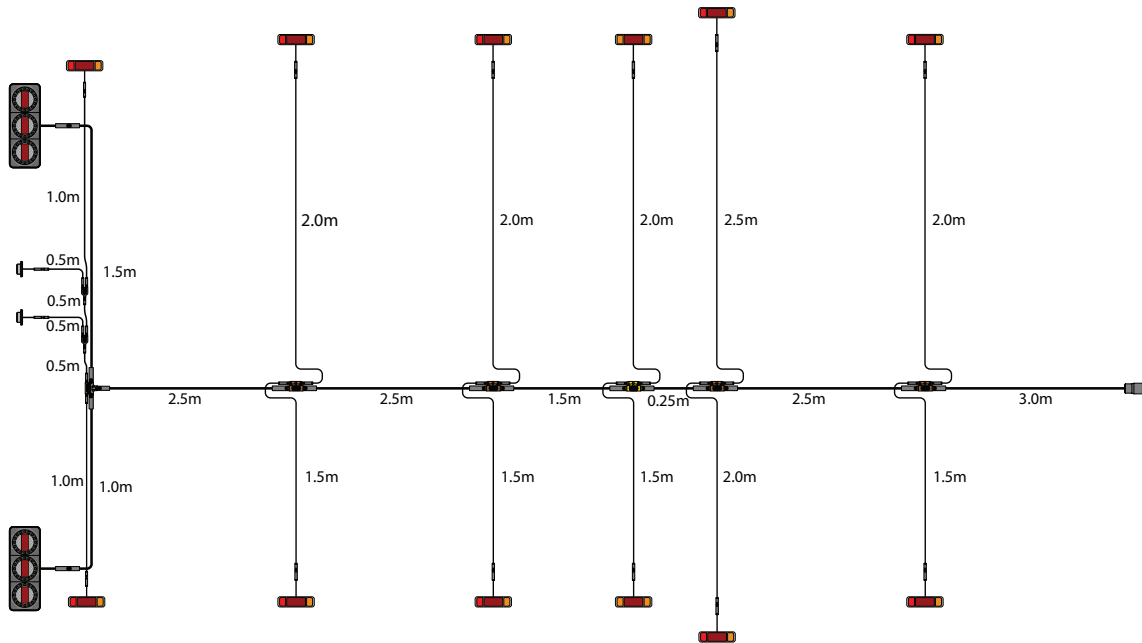
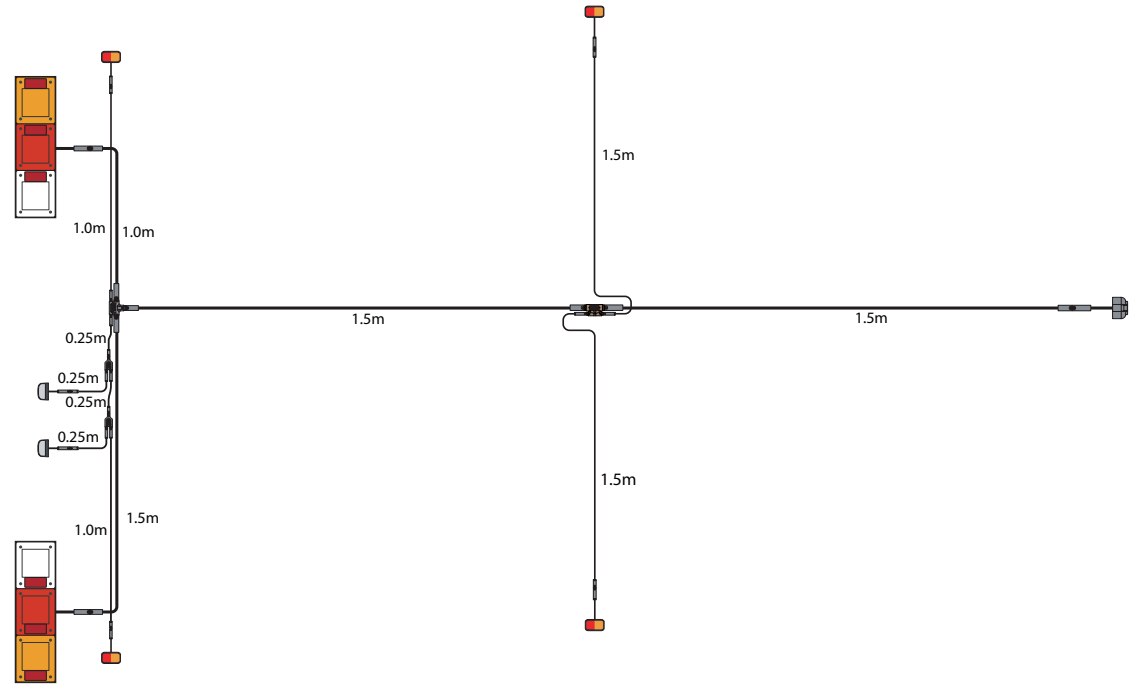

TRI AXLE TAG TRAILER

Standard Type Fuel Liquids Rigid/Tanker Trailer



RIGID TANKER
SCHEMATIC

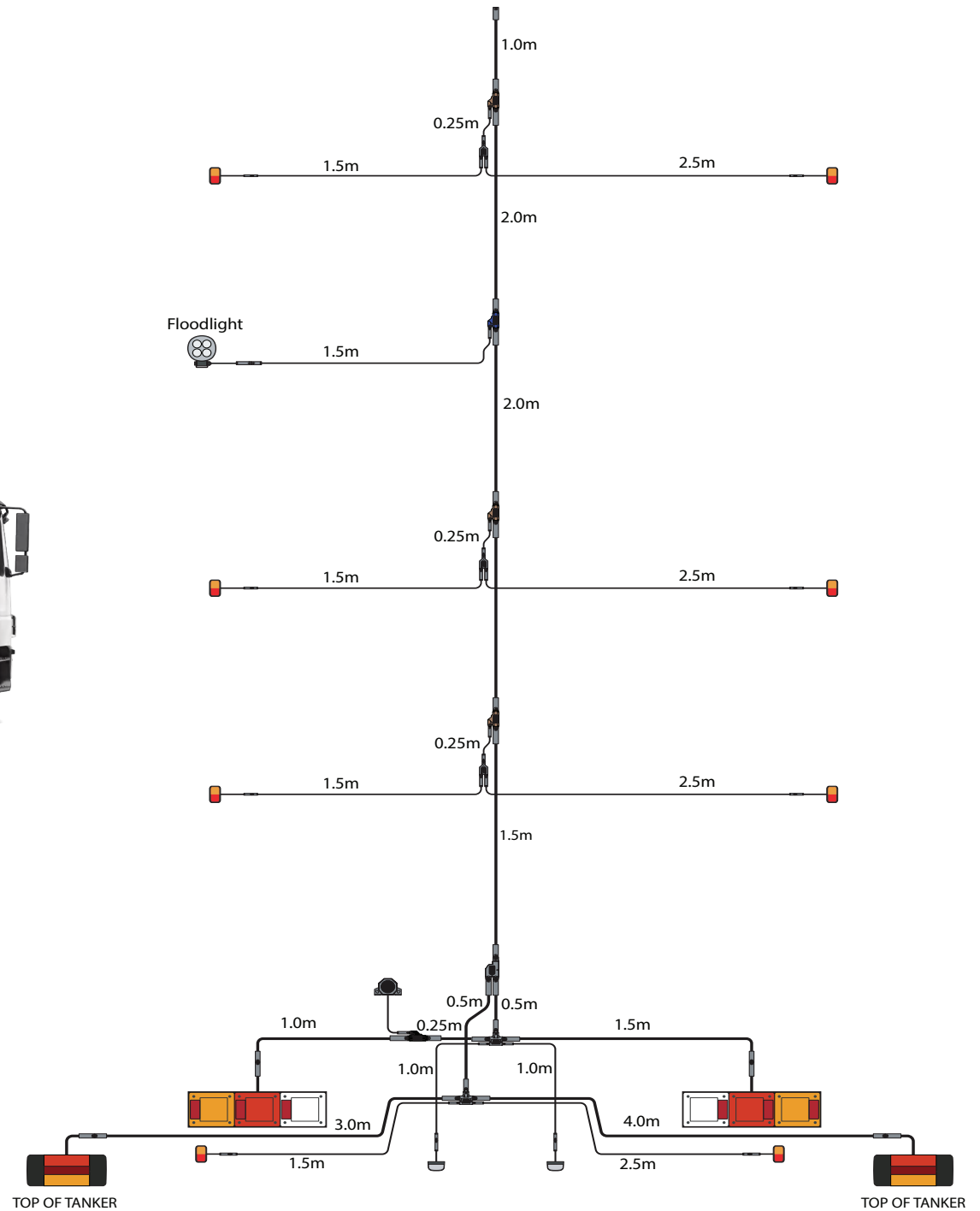



TANKER TRAILER
SCHEMATIC

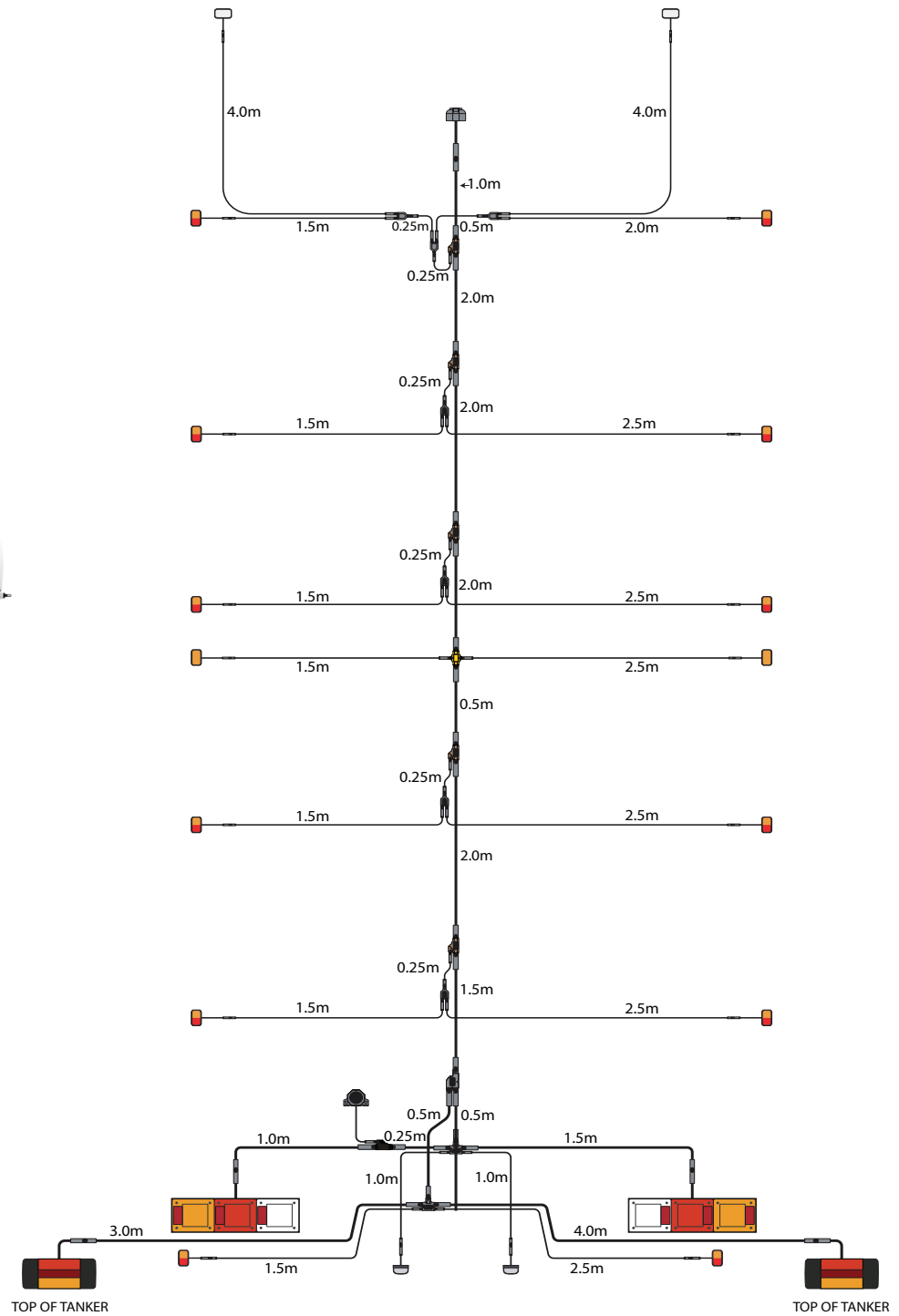

Rigid Tipper Dog/Pig Trailers



RIGID TIPPER
SCHEMATIC

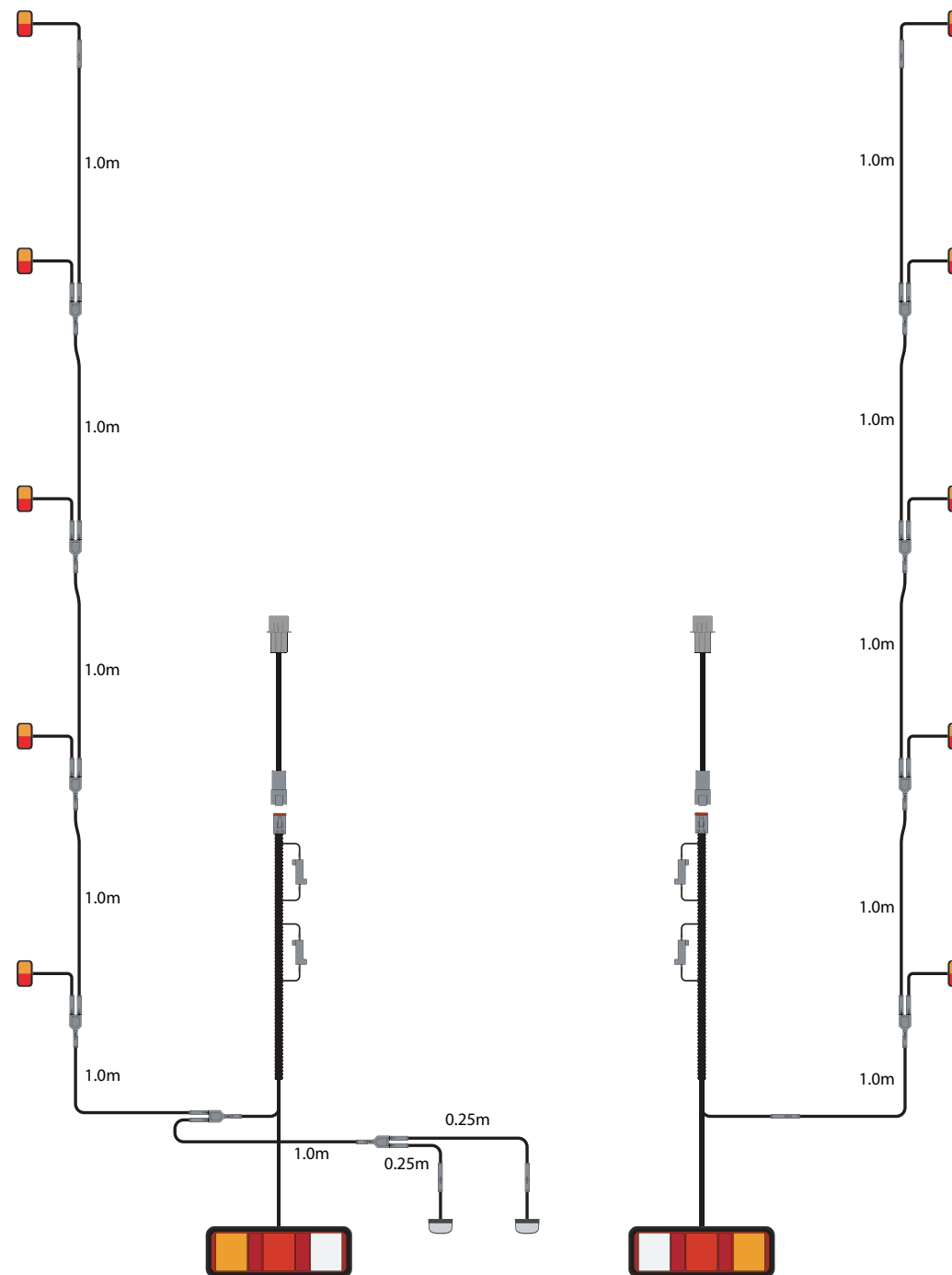



3 AXLE DOG TIPPER
SCHEMATIC

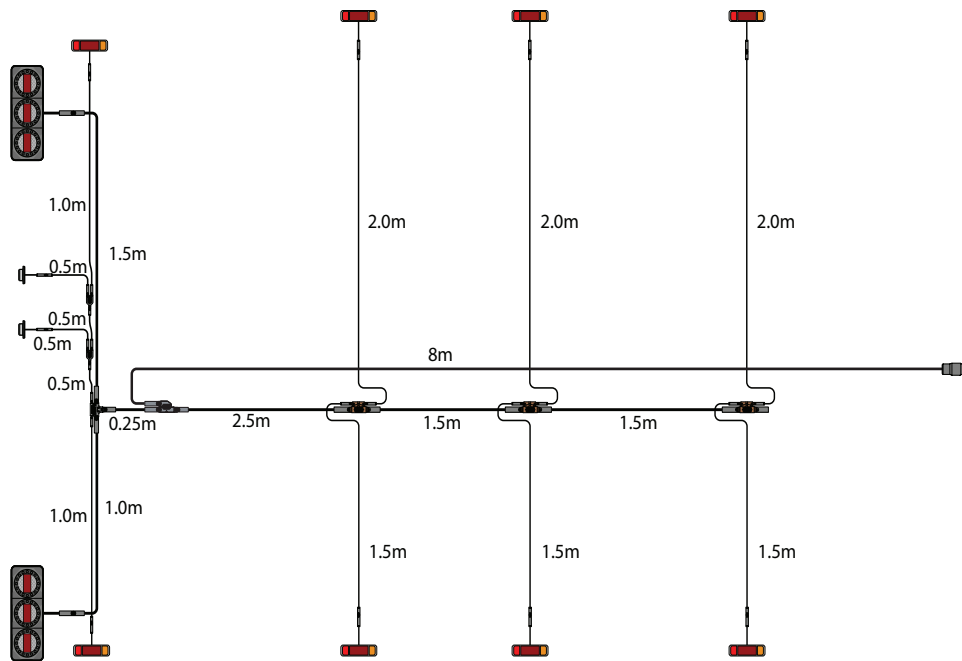
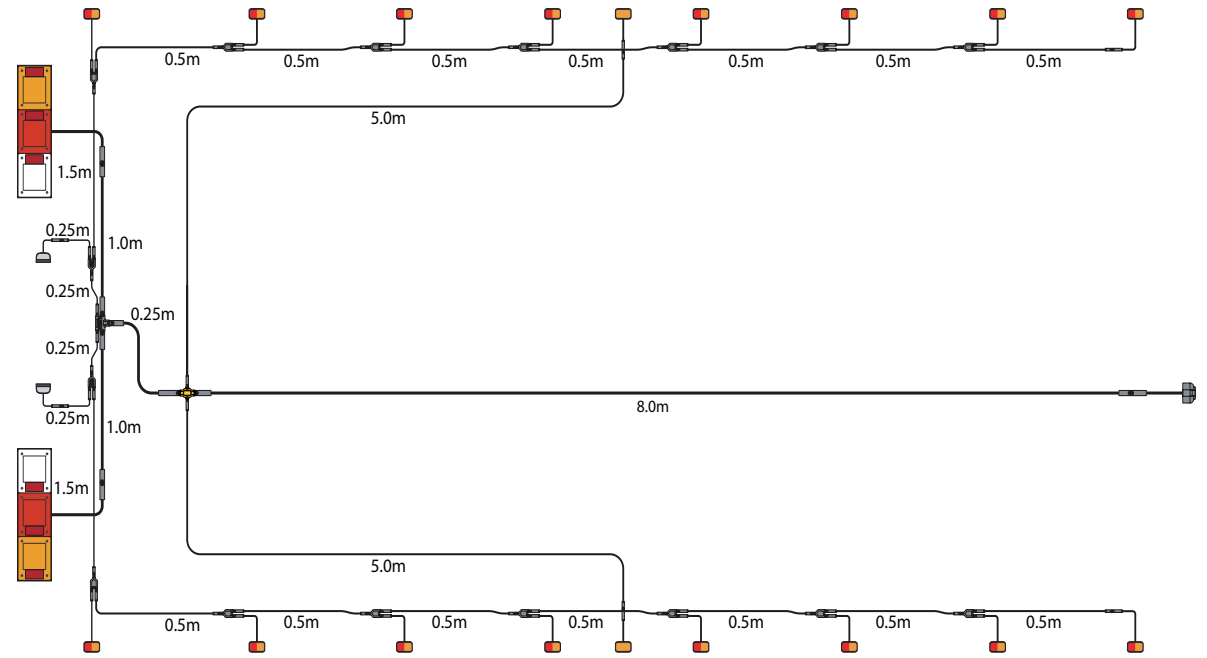

3 AXLE PIG TIPPER
SCHEMATIC

Rigid Tilt Tray Curtainsider/Tray

TILT TRAY
SCHEMATIC

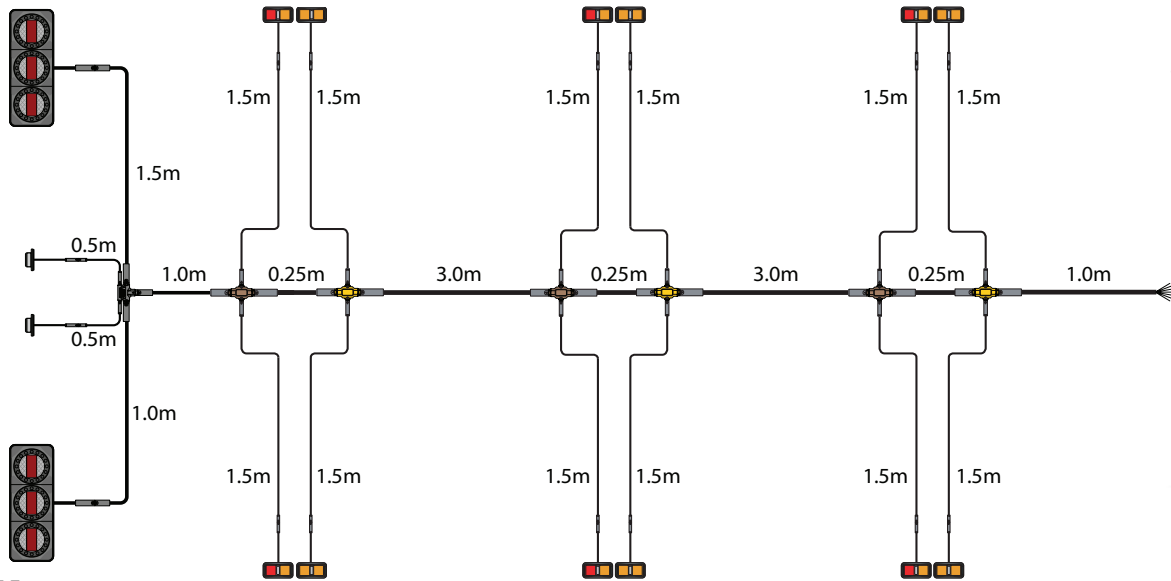
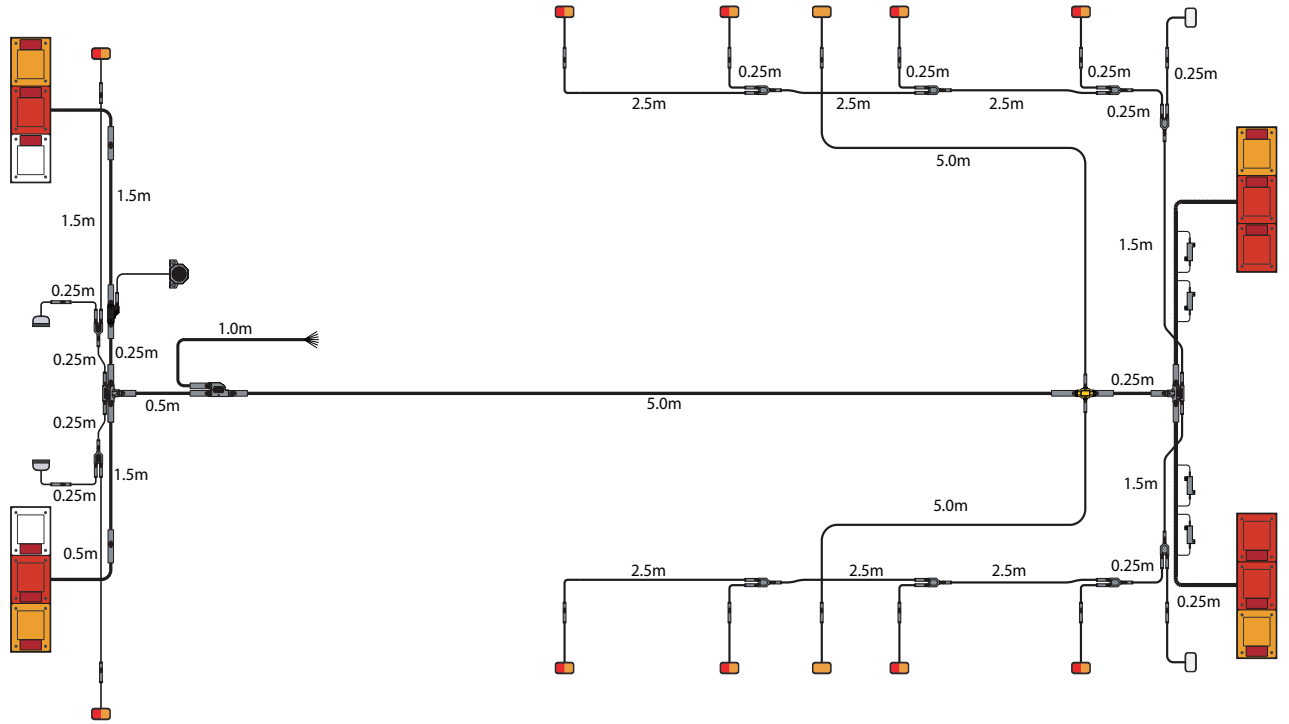

TRAY TRUCK
SCHEMATIC



CURTAINSIDER
SCHEMATIC

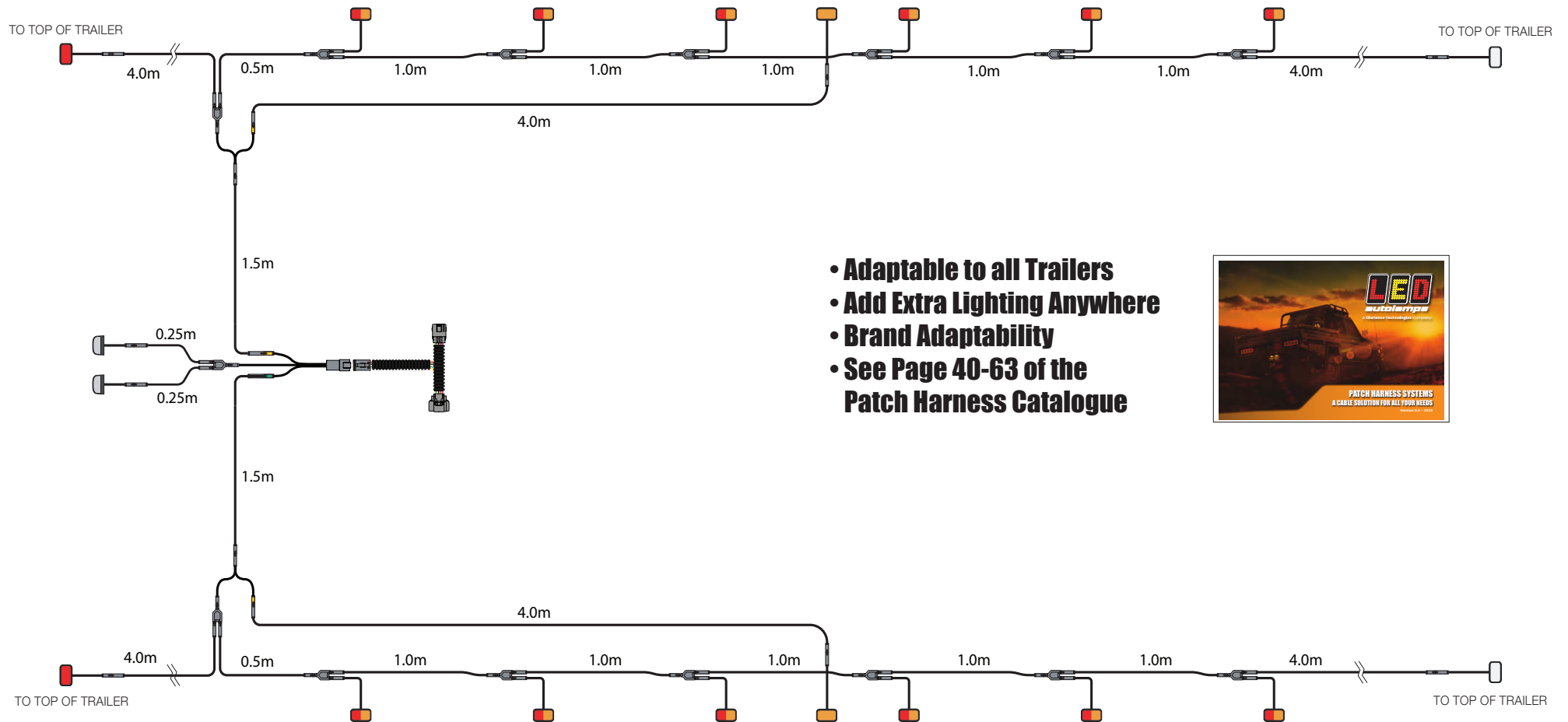

- **Adaptable to all Trailers**
- **Add Extra Lighting Anywhere**
- **Brand Adaptability**
- **See Page 40-63 of the Patch Harness Catalogue**



Side Lifters and Drop Decks



SIDE LIFTER
SCHEMATIC

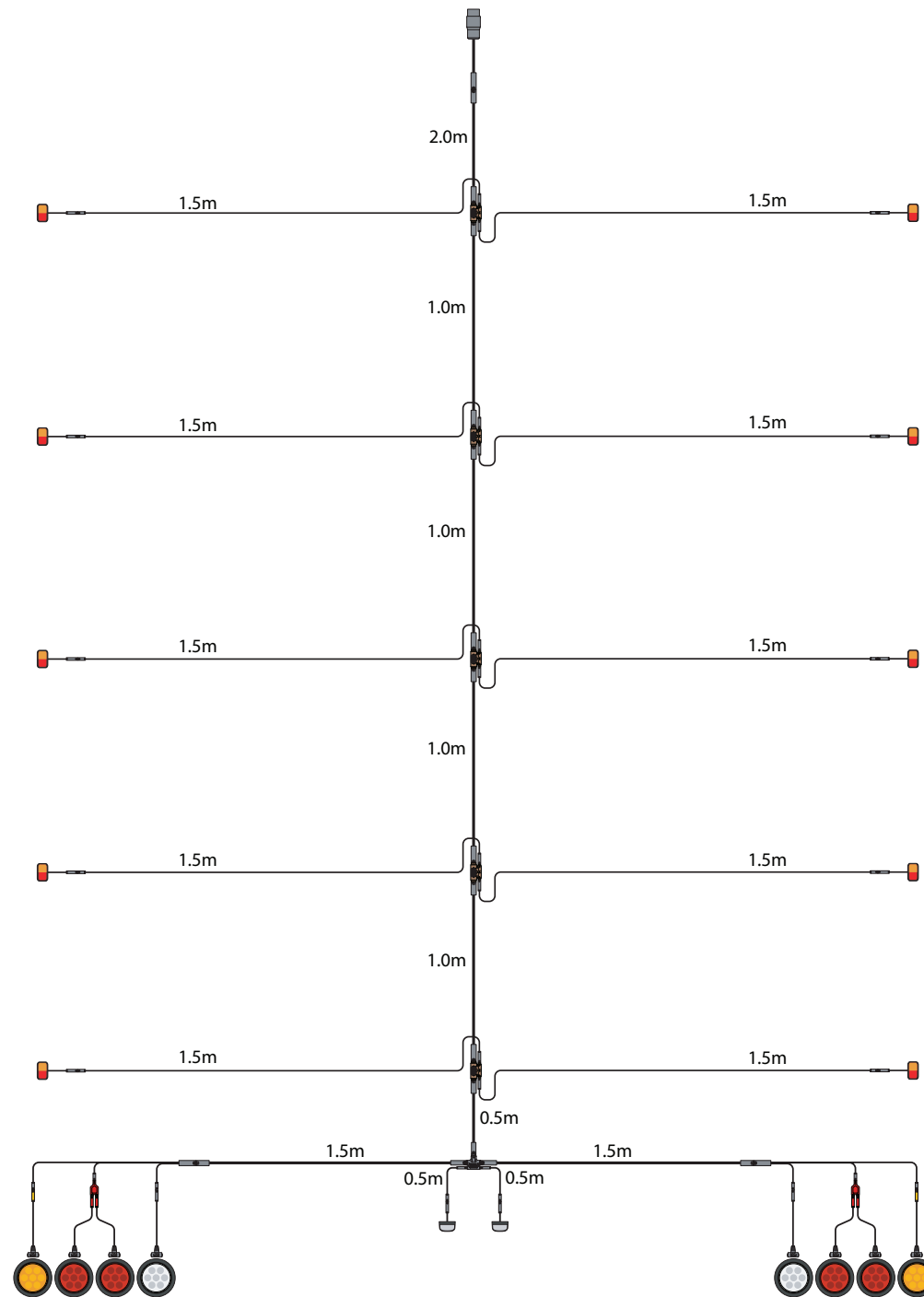



DROP DECK
SCHEMATIC

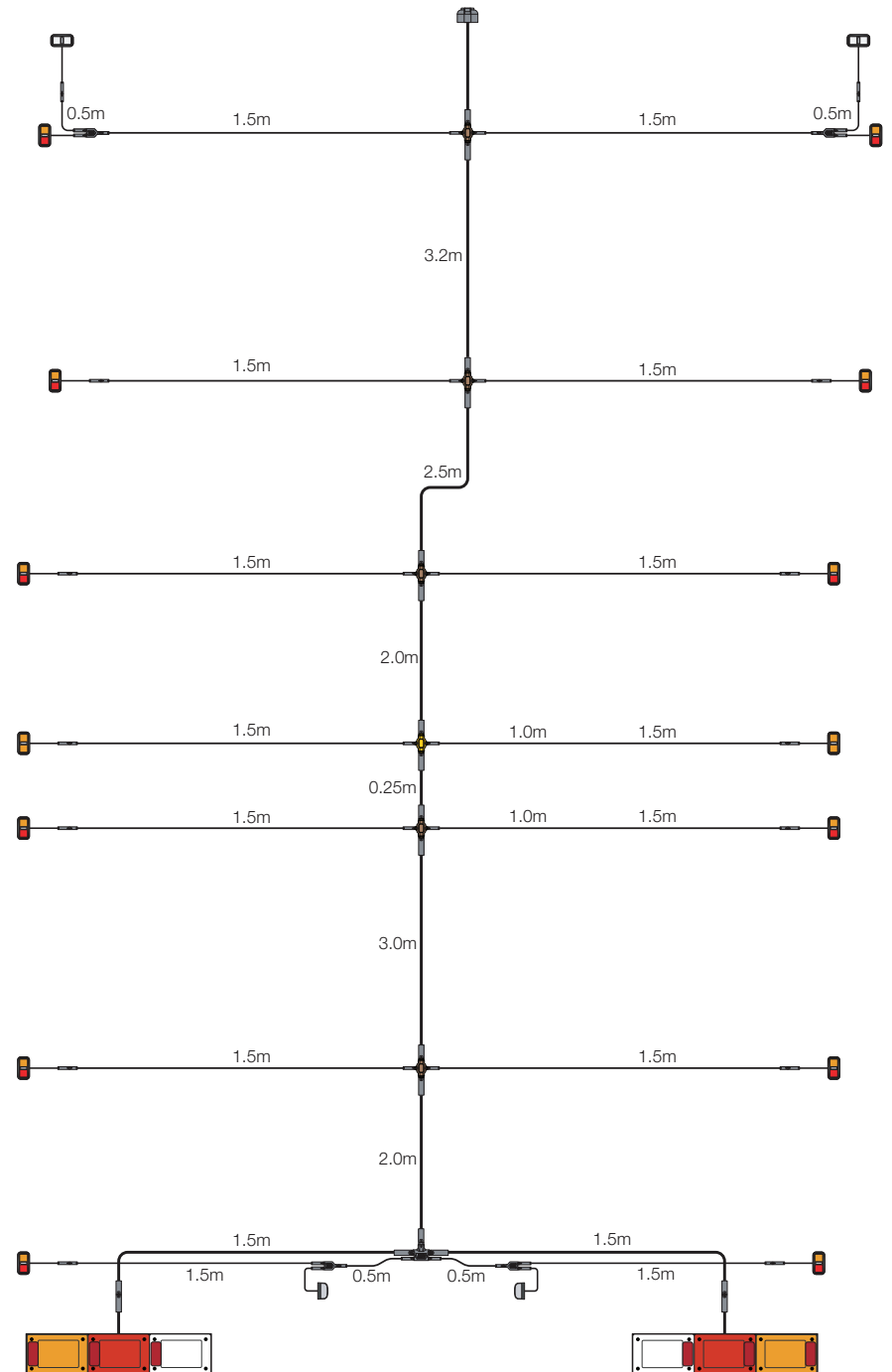

Road Train Adaptability to ADR 63/00 Vehicle Standards



Trailer compliance for use in road train is made possible with our range of Road Train Cables. We use a 7 Core (6mm) RTC cable that's Australian made, conforms to applicable standards and is professionally adapted to our cable harness and lighting system. Both options available have a total extended length of 5m, 13m, 14.5, 15.5m and 16m respectively and use high-quality 12V, ISO 1724 and 24V, ISO 1185/DIN 7579 corrosion-resistant aluminium 7 Pin sockets. The standard system also offers 2 Core and 7 Core harness plugs, whilst the Dropdeck cabling is suited to retractable skeletal trailers when combined with a retractable Suzi cable (See page 28/29). It also includes our cable harness and lighting system 7 Core plugs.

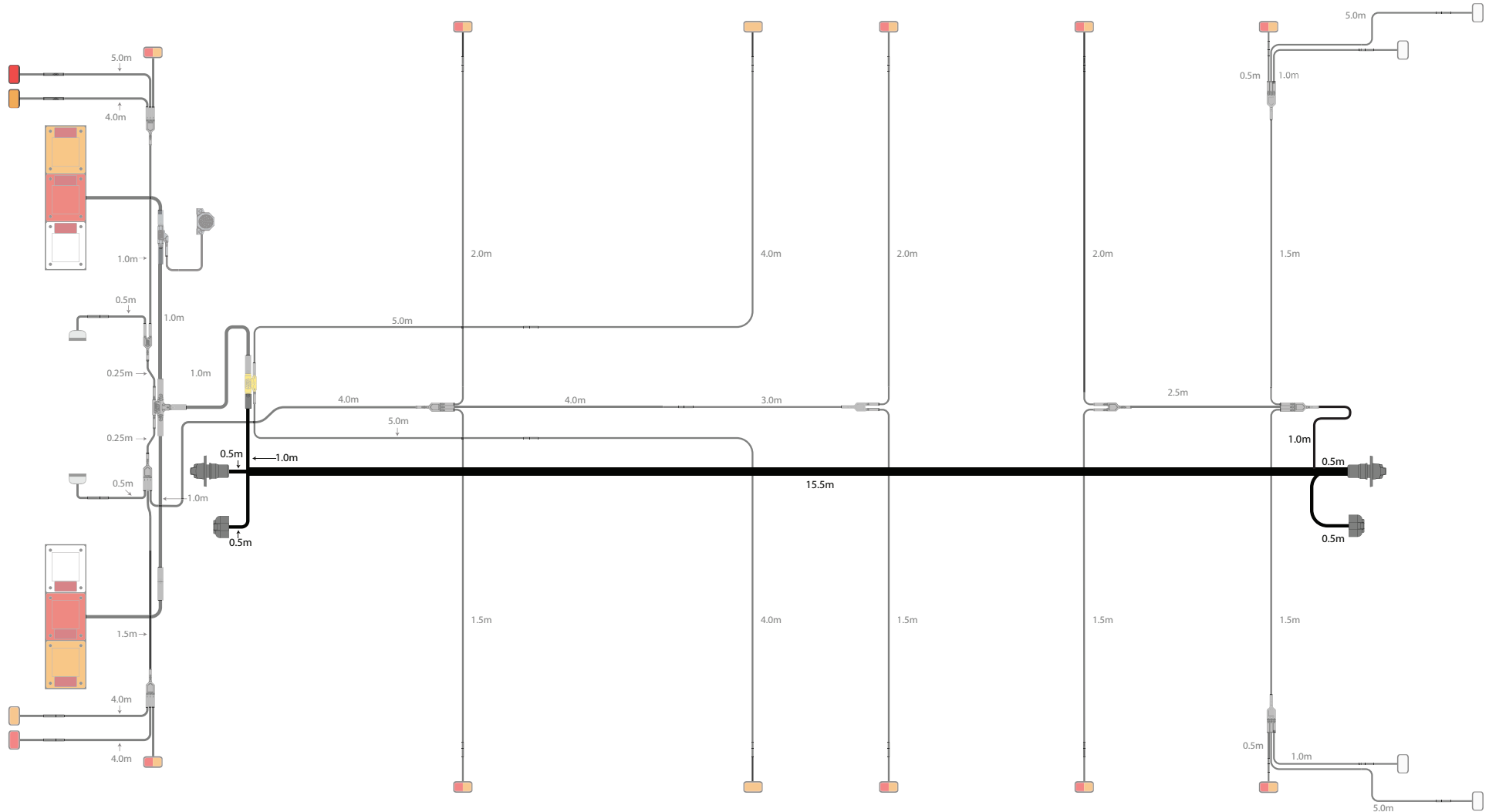

DROPDECK SCHEMATIC EXAMPLE ROAD TRAIN CABLE

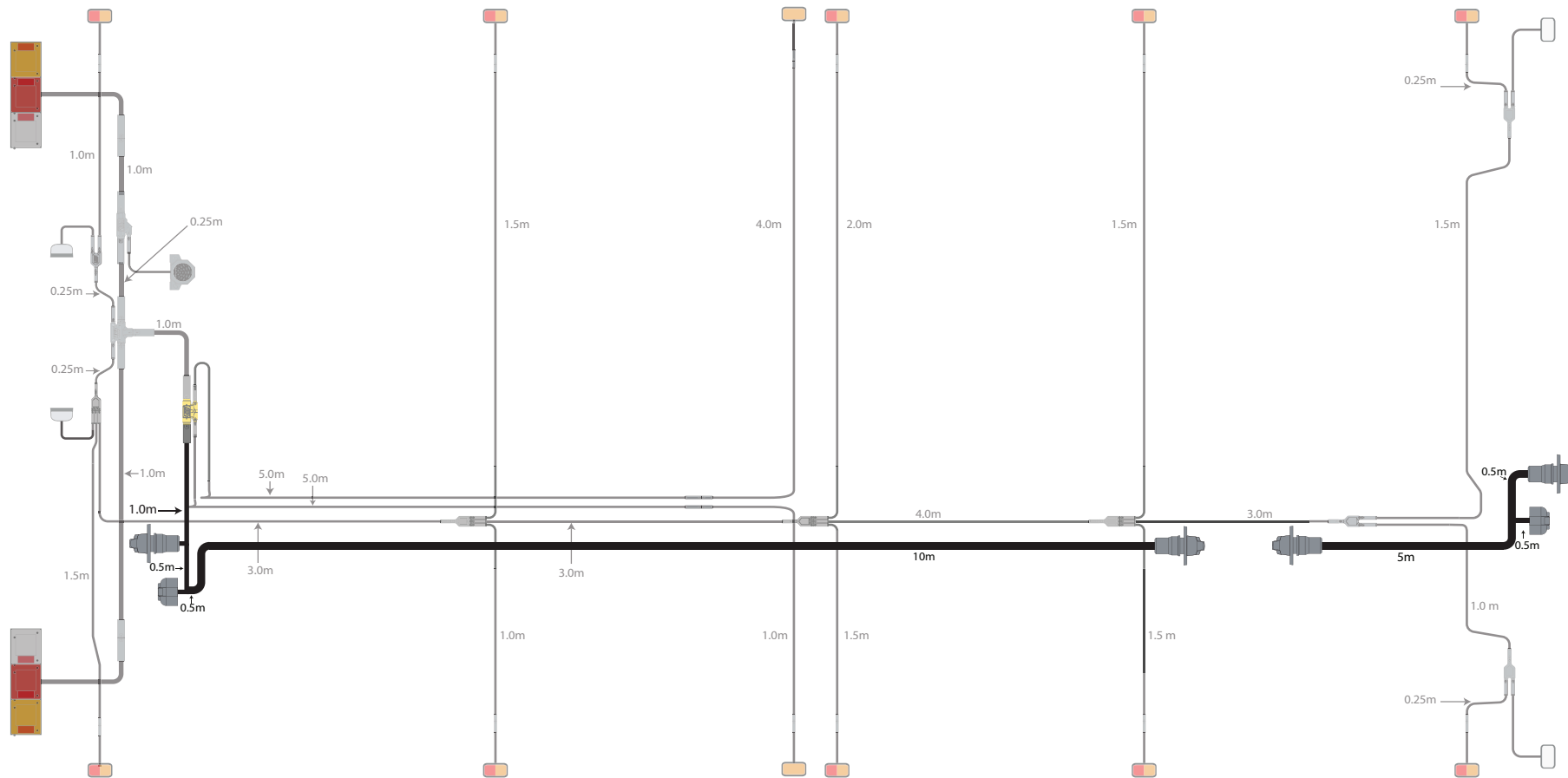

DROPDECK SCHEMATIC EXAMPLE ROAD TRAIN CABLE

Part No.	Cable Function
690-1062-01	6 METRES RETRACTABLE
690-1062-02	10 METRES RETRACTABLE
690-1063-01	5 METRES RETRACTABLE
690-1063-02	3 METRES RETRACTABLE
690-1064-01	DOLLY 5 METRES
690-1065-01	ROADTRAIN HARNESS 14.5 METRES
690-1065-02	ROADTRAIN HARNESS 15.5 METRES
690-1065-03	ROADTRAIN HARNESS 16 METRES
690-1065-04	ROADTRAIN HARNESS 13 METRES
HN-8300DRT	HARNESS, ROAD TRAIN DOLLY, 8.3M
HN-18100RTSP	FRONT CSB SPLICE SKT/PLG 18.1M

NOTE: ROAD TRAIN CABLE PART NUMBERS DO NOT INCLUDE PLUGS OR SOCKETS. (EXCEPT HN-18100RTSP)

PLEASE REFER TO PAGE 28 AND 29 FOR MORE INFORMATION.

NEW
NEW



PICTURES ARE FOR ILLUSTRATIVE PURPOSES ONLY AND ARE SUBJECT TO CHANGE



Clarience[™]
TECHNOLOGIES

Team of
Companies



LED Autolamps

439 Boundary Road

Truganina, Victoria 3029

Phone 1800 815 000

Email contact@eccosafety.com

Website www.ledautolamps.com

DISCLAIMER

LED Autolamps has made every effort to ensure that the measurements and information contained in this catalogue are correct and accurate. Before orders are placed, especially before any commencement of manufacturing, please check all measurements and information. LED Autolamps reserves the right to improve, modify the dimensional design and or make technical changes or discontinue or update designs without prior notice. However, we will take all measures to inform our customers if and when possible of any changes made. LED Autolamps will not accept liability of any kind due to misuse or abuse of any products not used as intended.

**Printed March 2026
Version 6.2**