



***autolamps***

A Clarience Technologies Company

# **CABLE HARNESS & LIGHTING SYSTEM**

Version 5.7 - 2024

# Functional, Long Lasting Quality

## Innovative Harness System

The key to this system is its flexibility, offering every conceivable option for various lighting functions to be added at any point in the truck harness line.

## Flexibility/Versatility

Cable lengths range from 0.25m to 15m combined with heavy duty connector covers for every plug and connector assembly point with a breaking strain exceeding 25kg, making this a heavy duty and robust truck harness assembly.

## Colour Coded

All assembly plugs are colour coded to their specific function. Example - The Brown plug is for Marker Lamps. When requiring a marker lamp, add a brown plug in the harness line. The Yellow (LHS) or Green (RHS) plug is for Side Direction Indicator Lamps. When requiring a Side Direction Indicator lamp, add a yellow or green plug whether left or right hand side in the harness line.

## DG Rating & Road Train

Cables and covers manufactured to comply with DG (Dangerous Goods) Rating. Inspected by Worksafe Victoria and in accordance with DG-150424-1, DG-150424-2 in relation to the electrical wiring requirements as it applies to dangerous goods road vehicle bulk tankers, in accordance for usage with petrol and gas tankers. Cabling and lighting comply with AS2809 parts 1 & 2. You can achieve *Road Train Compatibility to ADR 63/00 on all drawings using the 7 Core (6mm) RTC cable & plugs.* See Page 6 & 44-45 for more information.

## Labour Costs

Designed specifically to be easily and quickly installed without the need to cut, splice, solder, join or tape wire joins, reducing fitting times with its simple plug in design. Expect to reduce lighting assembly labour costs by up to 75%.

## Warranty

Five year warranty for all truck & trailer vehicles and a one year warranty for livestock carrying trailers.

**Plugin Cables**  
Page 8-10

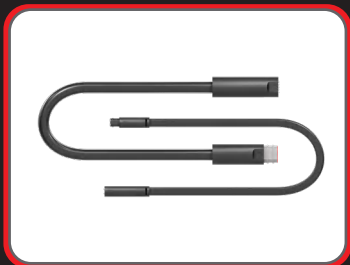

**Lighting**  
Page 11-18

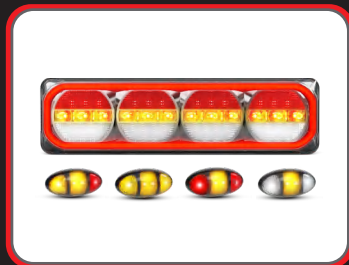

**Plugs/Covers**  
Page 19-23



**7P Trailer Sockets**  
Page 24-25



**Skel/Semi Trailer**  
Page 26-27



- **Add any Light Anywhere in the Harness System**
- **Easily Replace Damaged Lighting with Minimal Downtime**
- **Heavy Duty Water-resistant Cable, Plugs and Connectors**
- **Colour Coded Plugs to the Colour of the Wire Function**
- **All Large Vehicles and Trailers**
- **All Lights Compliant with ECE or ADR**
- **Cable System Compliant with Dangerous Goods (AS2809)**
- **All Drawings Compatible with Road Train (Page 6 & 44-45)**
- **5 Year Warranty, Livestock Transport 1 Year Warranty**
- **RoHS Compliant Cables, Plugs and Lights**

## Cable and Wire

TWP Cable (Thin wall thermo plastic) and PVC Automotive primary wire complying with SA-J1128, Annealed copper wire in compliance with ASTMB3, RoHS compliant Lead free copper wire with operating temperature between -40°C to +85°C - Harness system tested to B-Double requirements when LEDs are used. Please refer to wire gauge table below for further information regarding wire gauge and amperage.

Function	Wire Colour	Gauge	Rated Amp	Draw @13.8V	Maximum Lamps	Diameter (mm)	Area (mm <sup>2</sup> )	Resistance (Ohms/1000ft)
Earth	White	14	20	-	-	1.62814	2.08	2.525
Accessory	Blue	16	10	2.0A	-	1.29032	1.31	4.016
Stop	Red	18	8	0.47A	16 Lamps	1.02362	0.823	6.385
Left Indicator	Yellow	20	5	0.42A	10 Lamps	0.8128	0.518	10.15
Right Indicator	Green	20	5	0.42A	10 Lamps	0.8128	0.518	10.15
Marker	Brown	20	5	0.05A	120 Lamps	0.8128	0.518	10.15
Reverse	Black	20	5	0.59A	8 Lamps	0.8128	0.518	10.15

**Refrigerated/Curtainsider**  
Page 28-33



**A&B Coupling/Dolly/Tag**  
Page 34-35



**Tanker/Trailer**  
Page 36-37



**Rigid/Tilt/Tipper**  
Page 38-41



**Drop Deck/Road Train**  
Page 42-45



## Australian First Dual Function Marker/Indicator Lamp

Introducing the All-New 97 series side marker/indicator combination lamp, which is Australian road approved for Category five side direction indicator as well as an amber/red side marker. The lamps are large trailer plugin harness compatible, enabling them to be easily daisy-chained down the length of the vehicle or incorporated into existing harness setup. Adaptability allows you to add any combination of marker lamps or marker/indicator lamps.

**The standard function is an amber/red side marker. The override function is the side direction indicator. When the indicator is active, the marker is disabled. The Front and Rear end outline markers include supplementary indicators which are not ADR.**



**Front Marker Indicator Lamp**  
Page - 16  
Part No. 97WIMCSB  
Front End Outline Marker  
Supplementary Indicator



**Rear Marker Indicator Lamp**  
Page - 16  
Part No. 97RIMCSB  
Rear End Outline Marker  
Supplementary Indicator

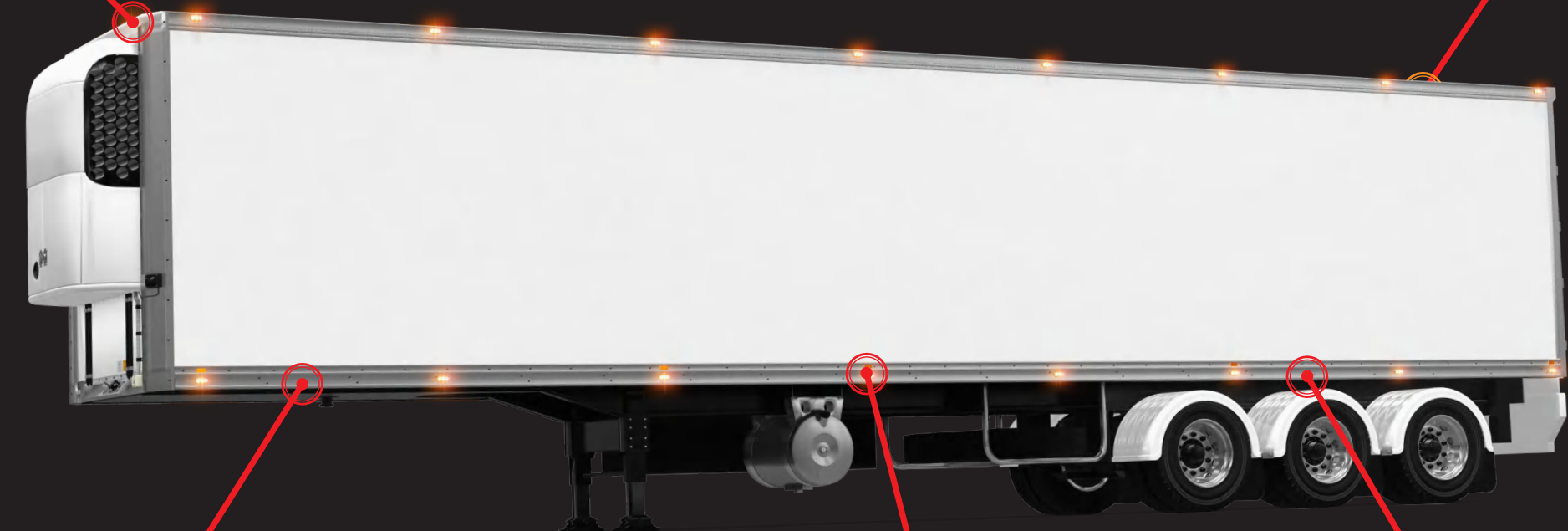

**LHS/RHS Indicator Splitter**  
Page - 21  
Part No. 7CILR3B  
Combination Left  
and Right Indicator



**Side Marker Indicator Lamp**  
Page - 16  
Part No. 97ARIMCSB  
Amber/Red Side Marker  
Side Direction Indicator



**Marker Indicator Splitter**  
Page - 21  
Part No. 3P3IMB  
3 Core 3 Way  
Indicator Splitter

## Single Function Lamp Adaptability Or Additional Lamps From Main Cable

Many customers still prefer to use the recessed type rectangle or round lights for their trailer builds. The 7CFS series of plugs allows this to happen by splitting from the main cable a series of individual cables and plugs to suit Stop/Tail Lamps, Indicator Lamps and Reverse Lamps.

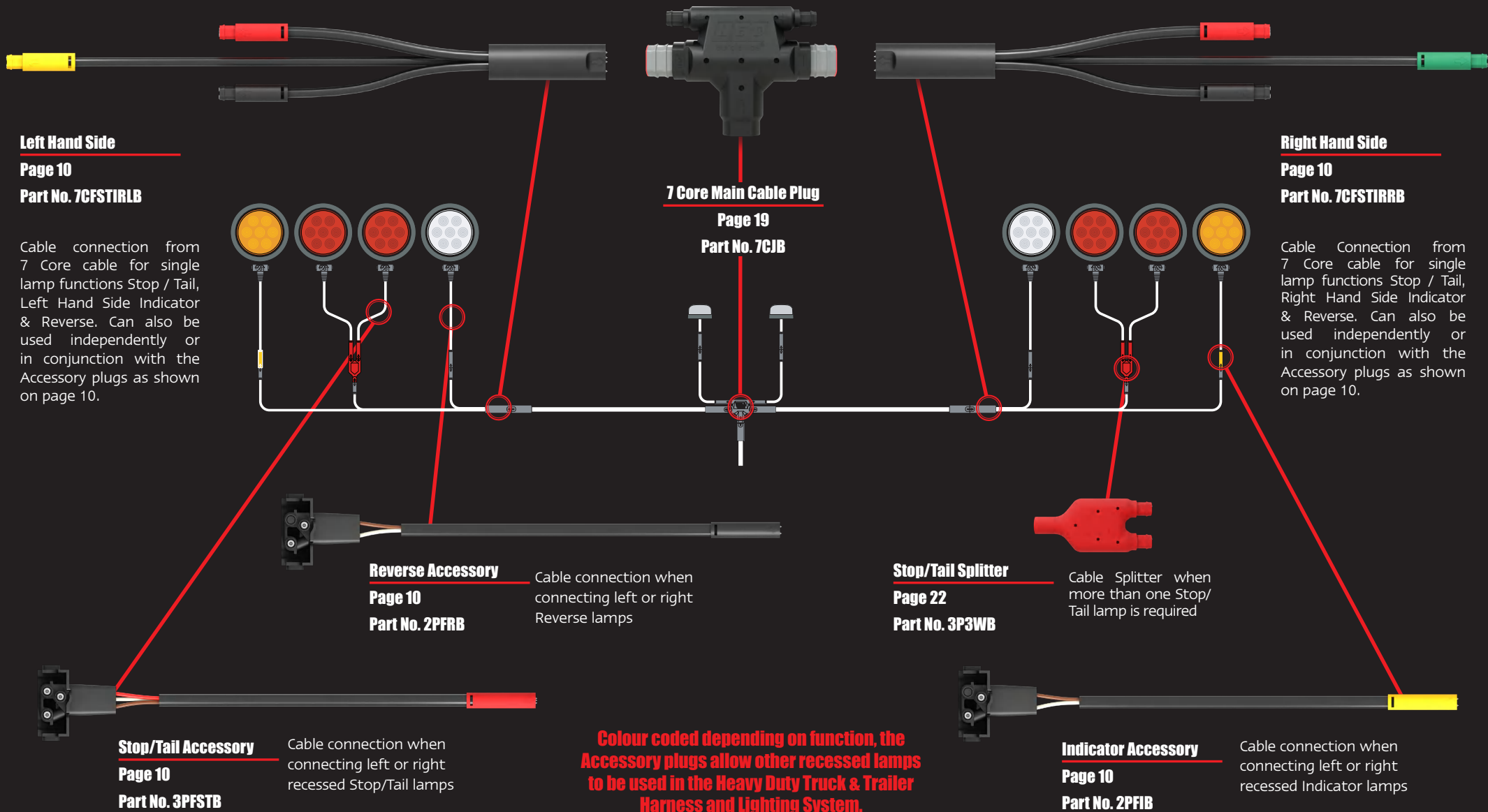

## Road Train Adaptability to ADR 63/00 Vehicle Standards

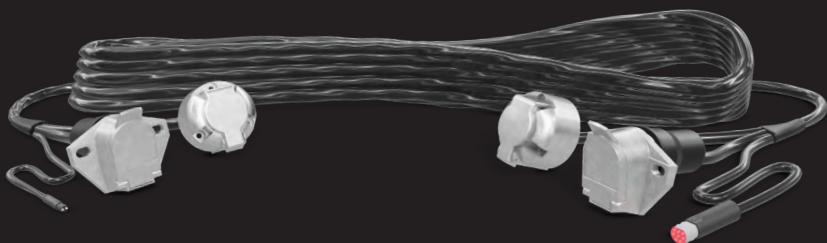

### Road Train Cable

Page 44-45

Part No. 7CRT-5M

Part No. 7CRT-145M

Part No. 7CRT-13M

Part No. 7CRT-155M

Part No. 7CRT-16M

ROAD TRAIN CABLE with 12V/24V or a 24V only (7CRT-5M) and 7 Pin Sockets at both ends with 2 Core & 7 Core plug adapter.

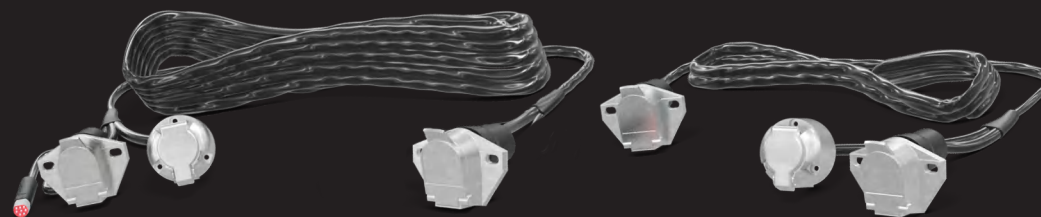

### Road Train Cable

Page 44-45

Part No. 7CRT.RT-6-5M

Part No. 7CRT.RT-10-3M

Part No. 7CRT.RT-10-5M

ROAD TRAIN CABLE for use with Retractable Suzi Cable. Includes 12V & 24V 7 Pin Sockets at the Rear includes the 7 Core plug adapter.

Trailer compliance for use in road train is made possible with our 7CRTC range of Road Train Cables. We use a 7 Core (6mm) RTC cable that's Australian made, conforms to applicable standards and is professionally adapted to our cable harness and lighting system. Both options available have a total extended length of 15.5m and use high-quality 12V, ISO 1724 and 24V, ISO 1185/ DIN 7579 corrosion-resistant aluminium 7 Pin sockets. The standard 7CRTC also offers 2 Core and 7 Core harness plugs, whilst the 7CRTCRT is suited to retractable skeletal trailers when combined with a retractable Suzi cable (See page 24-25). It also includes our cable harness and lighting system 7 Core plug.

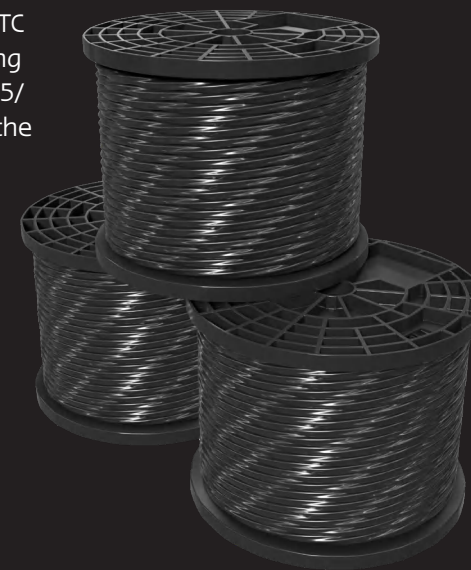

### Specifications

6.0mm Seven Core Cable Black Sheath

PVC Insulation to AS3191

Voltage Rating up to 110V

Strand Diameter: 0.3mm

Number of Strands: 65

Conductor Cross Section: 5.22mm<sup>2</sup>

Wire Colours: Green, Yellow, Blue, Red, White, Black, Brown

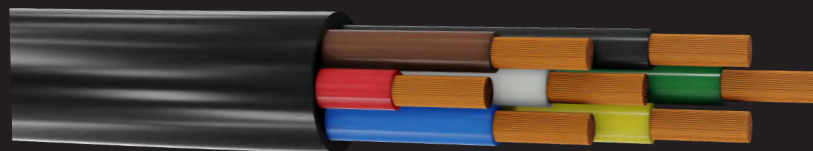

•ROHS •V90 •OXYGEN FREE •LEAD FREE PVC - E.L.V. ONLY

## Power Patch Cables For Vehicle Lighting

The Rigid body trucks can also benefit from this system with many possibilities to advance your lighting and wiring options. We now offer a range of Power Patch Cables that taps into the vehicle's existing rear lighting harness, enabling the addition of markers, high-level combination lamps or trailer sockets without time-consuming wiring. This innovative system will give you the flexibility and adaptability to compliment your O/E fitting requirements saving you time and money.

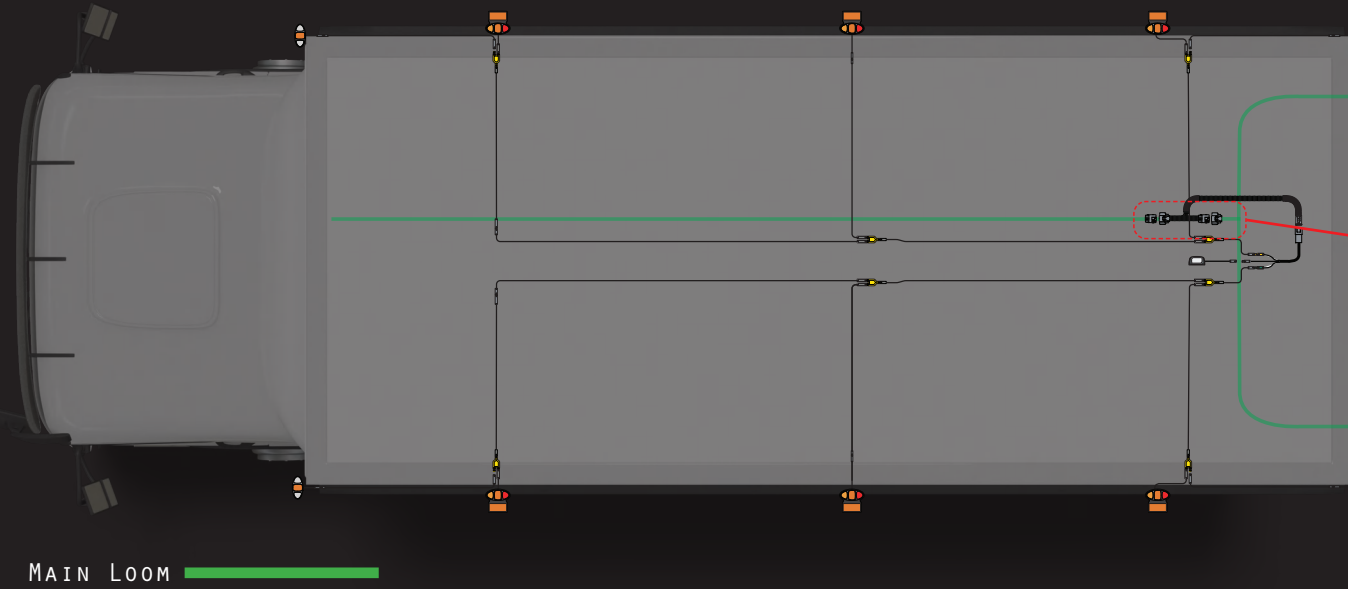

- Perfect for OEM Fitters
- Save Time & Money
- System Expandable
- System Customisable
- System Adaptability

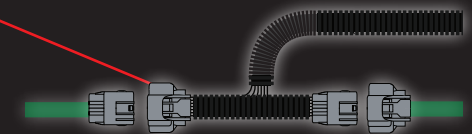

PATCHING INTO THE EXISTING LOOM USING A PPATCH POWER HARNESS

MAIN LOOM

**We have break-out patch cables to suit many Rigid Truck Brands. If you require a specific application, please call us to discuss your requirements.**



Detailed Explanation in Our Patch Harness Catalogue on page 38-61



## 7 Core Cables with Male & Female Plugs

The cable we have chosen for this harness system is used widely in the automotive industry and complies with SA-J1128 Standards. The cable width is 9.5mm, Male & Female plug diameter is 18mm. The plugs we have designed are 100% water-resistant, with a unique double sealing lip that will not allow water ingress. The covers for the plugs have been created for extra strength and engineered to a breaking strain of 25kg. The connection cover ensures a secure fitment and completes Dangerous Goods Rating AS2809.

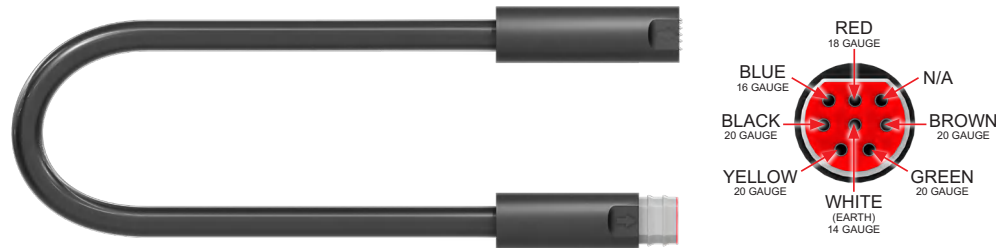

Part No.	Length
7CMF.25B	25 CENTIMETRES
7CMF.5B	50 CENTIMETRES
7CMF1B	1 METRE
7CMF1.5B	1.5 METRE
7CMF2B	2 METRE
7CMF2.5B	2.5 METRE
7CMF3B	3 METRE
7CMF4B	4 METRE
7CMF5B	5 METRE
7CMF6B	6 METRE
7CMF8B	8 METRE
7CMF10B	10 METRE
7CMF15B	15 METRE

## 2 Core Cables with Male & Female Plugs or Female Plugs with Bare Wires

The cable we have chosen for this harness system is used widely in the automotive industry and complies with SA-J1128 Standards. The cable width is 6mm, Male & Female plug diameter is 9mm. The plugs we have designed are 100% water-resistant, with a sealing lip that will not allow water ingress. The covers for the plugs have been created for extra strength and engineered to a breaking strain of 15kg. The connection cover ensures a secure fitment and completes Dangerous Goods Rating AS2809.



Part No.	Length
2PMF.25B	25 CENTIMETRES
2PMF.5B	50 CENTIMETRES
2PMF1B	1 METRE
2PMF1.5B	1.5 METRE
2PMF2B	2 METRE
2PMF2.5B	2.5 METRE
2PMF3B	3 METRE
2PMF4B	4 METRE
2PMF5B	5 METRE



Part No.	Length
2PF.25B	25 CENTIMETRES
2PF.5B	50 CENTIMETRES
2PF1B	1 METRE

JOINED PLUG IN COVER

CABLE PLUG COVER

3 WAY SPLITTER FOR 2 CORE CABLE

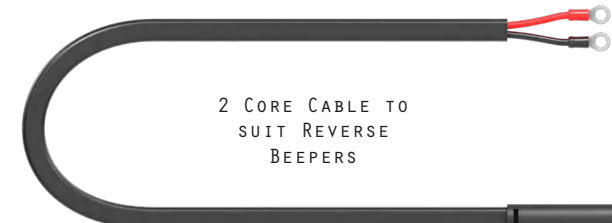

Part No.	Length
2PF200ETB - CABLE	20 CENTIMETRES



## 7 Core Cables with Male Plug and Bare Wires

The cable we have chosen for this harness system is used widely in the automotive industry and complies with SA-J1128 Standards. The cable width is 9.5mm, Male plug diameter is 18mm. The plugs we have designed are 100% water-resistant, with a unique double sealing lip that will not allow water ingress. The covers for the plugs have been created for extra strength and engineered to a breaking strain of 25kg. The connection cover ensures a secure fitment and completes Dangerous Goods Rating AS2809.

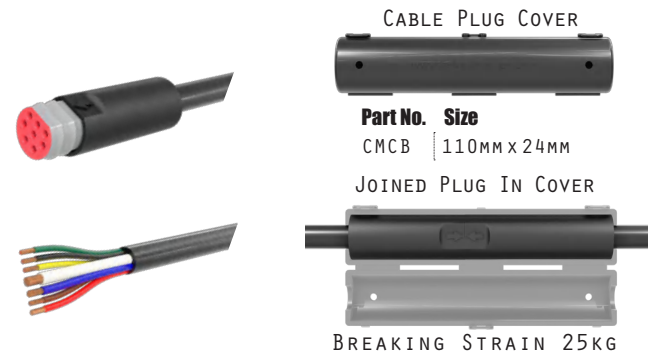
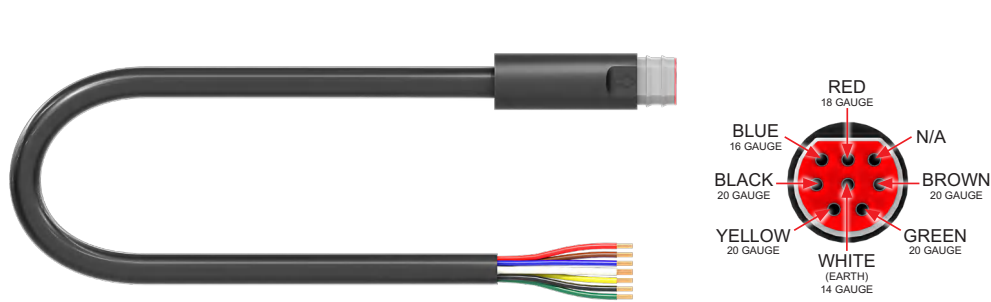

Part No.	Length
7CM1B	1 METRE
7CM2B	2 METRE
7CM3B	3 METRE

## 3 Core Cables with Male & Female Plugs

The cable we have chosen for this harness system is used widely in the automotive industry and complies with SA-J1128 Standards. The plugs we have designed are 100% water-resistant, with a sealing lip that will not allow water ingress.

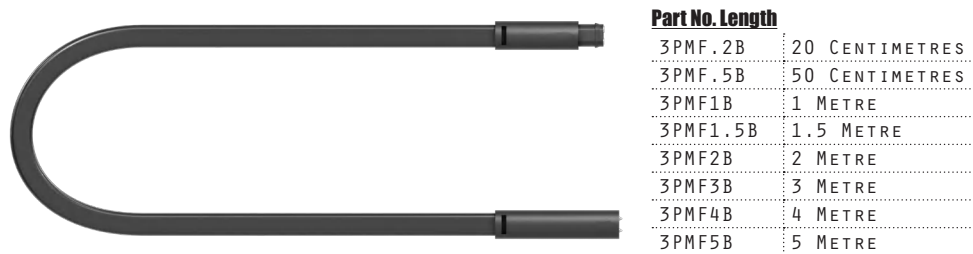

JOINED PLUG IN COVER



BREAKING STRAIN 15KG

CABLE PLUG COVER



Part No. Size  
2PCB 72MM x 15MM

## 16 Gauge Cables for the Accessory Blue Wire

The heavy-duty truck harness system has provisions for an accessory product fitted via the 16 gauge blue wire. Plugin one of the adapter plugs into the harness system, then run a 2 Core cable to connect an accessory product.

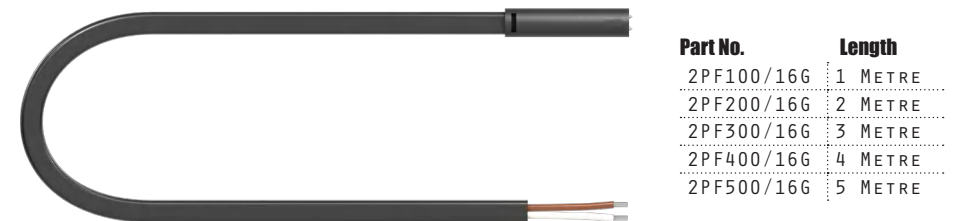

**Important Note;** Work lights on the harness system are an accessory and should be connected to the blue wire and not the reverse (black) wire. The maximum size work lamps allowable on the blue wire are 120 watts in a 12 volt system and 240 watts in a 24 volt system. If you need to run work lamps at the same time as the reverse light then the blue wire can be connected to the reverse wire at the front of the trailer.

## Cables for Single Function Lamps

Many customers still prefer to use the recessed type rectangle or round lights for their trailer builds. The 7CFS series of plugs allows this to happen by splitting from the main cable a series of individual cables and plugs to suit 1) Stop/Tail Lamp 2) Indicator Lamp 3) Reverse Lamp.



Part No.	Cable Function	Length
7CFSTIRLB	LEFT SIDE MAIN CABLE CONNECTOR FOR STOP/TAIL/INDICATOR/REVERSE	140MM RED/BLACK 200MM YELLOW



Part No.	Cable Function	Length
7CFSTIRR	RIGHT SIDE MAIN CABLE CONNECTOR FOR STOP/TAIL/INDICATOR/REVERSE	140MM RED/BLACK 200MM GREEN



Part No.	Cable Function	Length
7CFSTILB	LEFT SIDE MAIN CABLE CONNECTOR FOR STOP/TAIL/INDICATOR	140MM RED 200MM YELLOW



Part No.	Cable Function	Length
7CFSTIRB	RIGHT SIDE MAIN CABLE CONNECTOR FOR STOP/TAIL/INDICATOR	140MM RED 200MM GREEN

## Accessory Plugs for Individual Single Function Lamps

Colour coded depending on the function, the Accessory plugs allow other single-function recessed lamps that use the standard 3 Pin connectors to be used in the harness system.



Part No.	Cable Function	Length
3PFSTB	STOP/TAIL FUNCTION	200MM



Part No.	Cable Function	Length
2PFIB	REAR INDICATOR FUNCTION	200MM



Part No.	Cable Function	Length
2PFRB	REVERSE FUNCTION	200MM

## Single Function Lamps with Plugin Cable Connector

Note: Visit our website, [www.ledautolamps.com](http://www.ledautolamps.com) for further specifications and mounting information.

### 102 Series - SIZE 130MM ROUND X 12MM



20CM  
CABLE  
WITH  
PLUG

**Part No.** 102RMCB | **Function** STOP/TAIL



20CM  
CABLE  
WITH  
PLUG

**Part No.** 102AMCB | **Function** INDICATOR



20CM  
CABLE  
WITH  
PLUG

**Part No.** 102WMCB | **Function** REVERSE

### 132 Series - SIZE 130MM X 86MM X 16MM



20CM  
CABLE  
WITH  
PLUG

**Part No.** 132RMCB | **Function** STOP/TAIL



20CM  
CABLE  
WITH  
PLUG

**Part No.** 132AMCB | **Function** INDICATOR



20CM  
CABLE  
WITH  
PLUG

**Part No.** 132WMCB | **Function** REVERSE



**Part No.** 59401 | **Function** GROMMET

## Single Function Lamps Available for use with Accessory Plugs

### 113 Series - SIZE 109MM ROUND X 12MM



**Part No.** 113RMB | **Function** STOP/TAIL



**Part No.** 113AMB | **Function** INDICATOR



**Part No.** 113WMB | **Function** REVERSE



**Part No.** 53401 | **Function** GROMMET

### 110 Series - SIZE 109MM ROUND X 12MM

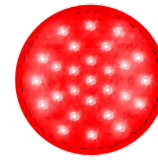

**Part No.** 110RMB | **Function** STOP/TAIL



**Part No.** 110AMB | **Function** INDICATOR

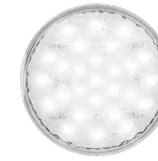

**Part No.** 110WMB | **Function** REVERSE



**Part No.** 53101 | **Function** GROMMET

### 130 Series - SIZE 134MM X 86MM X 16MM



**Part No.** 130RMB | **Function** STOP/TAIL/  
REFLECTOR



**Part No.** 130AMB | **Function** INDICATOR



**Part No.** 130WMB | **Function** REVERSE



**Part No.** 59401 | **Function** GROMMET

### 134 Series - SIZE 134MM X 86MM X 16MM



**Part No.** 134RMB | **Function** STOP/TAIL/  
REFLECTOR



**Part No.** 134AMB | **Function** INDICATOR/  
REFLECTOR



**Part No.** 134WMB | **Function** REVERSE/  
REFLECTOR



**Part No.** 59401 | **Function** GROMMET

# Rear Combination Lamps

Note: Visit our website, [www.ledautolmaps.com](http://www.ledautolmaps.com) for further specifications and mounting information.



## 200 Series - SIZE 200MM X 134MM X 28MM

Part No	Function	Side	Cable
200CCARRMLCSB	STOP/TAIL/INDICATOR	LEFT	20CM WITH PLUG
200CCARRMRCB	STOP/TAIL/INDICATOR	RIGHT	20CM WITH PLUG

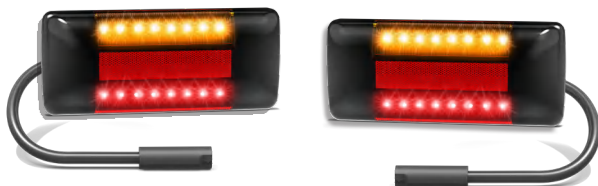

## 223 Series - SIZE 223MM X 96MM X 25MM

Part No	Function	Side	Cable
223BARMLCSB	STOP/TAIL/INDICATOR	LEFT	20CM WITH PLUG
223BARMRCB	STOP/TAIL/INDICATOR	RIGHT	20CM WITH PLUG



## 280 Series - SIZE 282MM X 95MM X 28MM

Part No	Function	Side	Cable
280ARRMLCSB	STOP/TAIL/INDICATOR/REFLECTOR	LEFT	20CM WITH PLUG
280ARRMRCB	STOP/TAIL/INDICATOR/REFLECTOR	RIGHT	20CM WITH PLUG
280ARWMLCSB	STOP/TAIL/INDICATOR/REVERSE/REFLECTOR	LEFT	20CM WITH PLUG
280ARWMRCB	STOP/TAIL/INDICATOR/REVERSE/REFLECTOR	RIGHT	20CM WITH PLUG

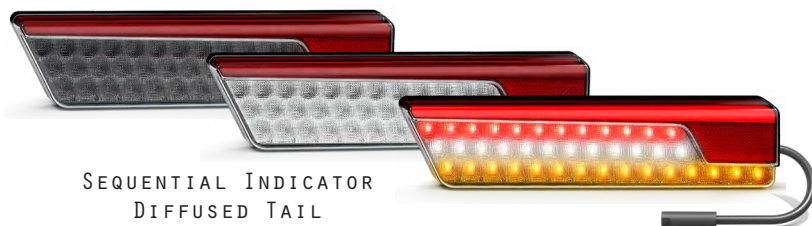

SEQUENTIAL INDICATOR  
DIFFUSED TAIL

## 355 Series - SIZE 356MM X 86MM X 35MM

Part No	Function	Side	Cable
355BARWMLCSB	STOP/TAIL/IND/REV/REF - BLACK CHROME	LEFT	40CM WITH PLUG
355BARWMRCB	STOP/TAIL/IND/REV/REF - BLACK CHROME	RIGHT	40CM WITH PLUG
355ARWMLCSB	STOP/TAIL/IND/REV/REF - CHROME	LEFT	40CM WITH PLUG
355ARWMRCB	STOP/TAIL/IND/REV/REF - CHROME	RIGHT	40CM WITH PLUG

# Rear Combination Lamps

Note: Visit our website, [www.ledautolamps.com](http://www.ledautolamps.com) for further specifications and mounting information.



SEQUENTIAL INDICATOR  
DIFFUSED TAIL

## 385 Series - SIZE 387MM X 105MM X 30.5MM

Part No	Function	Side	Cable
385ARWMLCSB	STOP/TAIL/INDICATOR/REV, DIFFUSED TAIL	LEFT	40CM WITH PLUG
385ARWMRCB	STOP/TAIL/INDICATOR/REV, DIFFUSED TAIL	RIGHT	40CM WITH PLUG



## 3851 Series - SIZE 387MM X 105MM X 30.5MM

Part No	Function	Side	Cable
3851ARWMLCSB	STOP/TAIL/INDICATOR/REVERSE/REFLECTOR	LEFT	40CM WITH PLUG
3851ARWMRCB	STOP/TAIL/INDICATOR/REVERSE/REFLECTOR	RIGHT	40CM WITH PLUG



DIFFUSED TAIL

## 3852 Series - SIZE 387MM X 105MM X 30.5MM

Part No	Function	Side	Cable
3852ARWMLCSB	STOP/TAIL/INDICATOR/REV, DIFFUSED TAIL	LEFT	40CM WITH PLUG
3852ARWMRCB	STOP/TAIL/INDICATOR/REV, DIFFUSED TAIL	RIGHT	40CM WITH PLUG

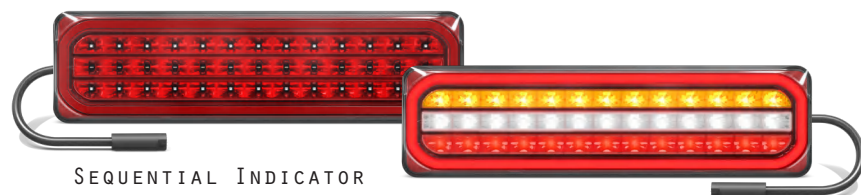

SEQUENTIAL INDICATOR  
DIFFUSED TAIL

## 3853 Series - SIZE 387MM X 105MM X 30.5MM

Part No	Function	Side	Cable
3853ARWMLCSB	STOP/TAIL/INDICATOR/REV, DIFFUSED TAIL	LEFT	40CM WITH PLUG
3853ARWMRCB	STOP/TAIL/INDICATOR/REV, DIFFUSED TAIL	RIGHT	40CM WITH PLUG

# Rear Combination Lamps

Note: Visit our website, [www.ledautolmaps.com](http://www.ledautolmaps.com) for further specifications and mounting information.

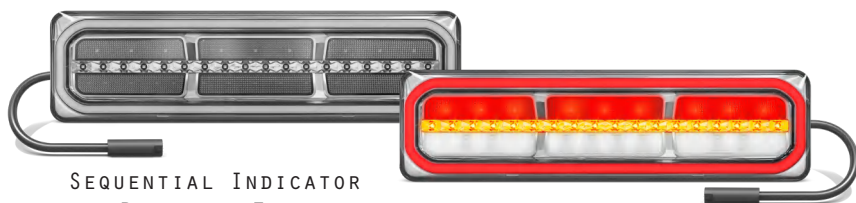

SEQUENTIAL INDICATOR  
DIFFUSED TAIL

## 3854 Series - SIZE 387MM x 105MM x 30.5MM

Part No	Function	Side	Cable
3854ARWMLCSB	STOP/TAIL/INDICATOR/REV, RED DIFFUSED TAIL	LEFT	40CM WITH PLUG
3854ARWMRCSB	STOP/TAIL/INDICATOR/REV, RED DIFFUSED TAIL	RIGHT	40CM WITH PLUG
38541ARWMLCSB	STOP/TAIL/INDICATOR/REV, GREY DIFFUSED TAIL	LEFT	40CM WITH PLUG
38541ARWMRCSB	STOP/TAIL/INDICATOR/REV, GREY DIFFUSED TAIL	RIGHT	40CM WITH PLUG



DIFFUSED TAIL

## 3855 Series - SIZE 387MM x 105MM x 30.5MM

Part No	Function	Side	Cable
3855ARWMLCSB	STOP/TAIL/INDICATOR/REVERSE, DIFFUSED TAIL	LEFT	40CM WITH PLUG
3855ARWMRCSB	STOP/TAIL/INDICATOR/REVERSE, DIFFUSED TAIL	RIGHT	40CM WITH PLUG



## 460 Series - SIZE 460MM x 130MM x 33MM

Part No	Function	Side	Cable
460ARRMLCSB	STOP/TAIL/INDICATOR/REFLECTORS	LEFT	20CM WITH PLUG
460ARRMRCSB	STOP/TAIL/INDICATOR/REFLECTORS	RIGHT	20CM WITH PLUG
460ARWMLCSB	STOP/TAIL/INDICATOR/REVERSE/REFLECTORS	LEFT	20CM WITH PLUG
460ARWMRCSB	STOP/TAIL/INDICATOR/REVERSE/REFLECTORS	RIGHT	20CM WITH PLUG

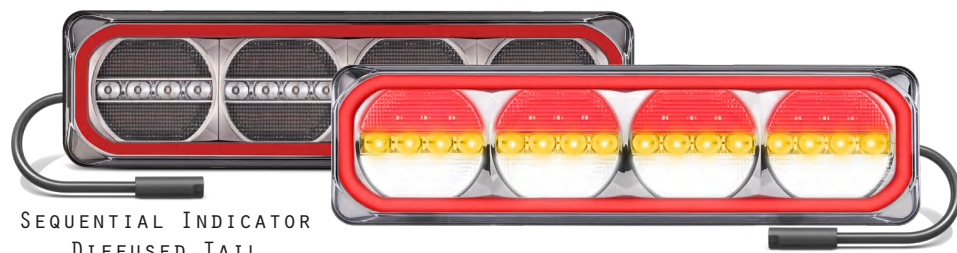

SEQUENTIAL INDICATOR  
DIFFUSED TAIL

## 520 Series - SIZE 520MM x 141MM x 28.5MM

Part No	Function	Side	Cable
520ARWMLCSB	STOP/TAIL/INDICATOR/REV, DIFFUSED TAIL	LEFT	40CM WITH PLUG
520ARWMRCSB	STOP/TAIL/INDICATOR/REV, DIFFUSED TAIL	RIGHT	40CM WITH PLUG

# Rear Combination Lamps

Note: Visit our website, [www.ledautolamps.com](http://www.ledautolamps.com) for further specifications and mounting information.



## J3 Series - SIZE 595MM X 130MM X 45MM

Part No	Function	Side	Cable
J3BARRMLCSB	STOP/TAIL/INDICATOR/REFLECTORS	LEFT	20CM WITH PLUG
J3BARRMRCB	STOP/TAIL/INDICATOR/REFLECTORS	RIGHT	20CM WITH PLUG
J3BARWMLCSB	STOP/TAIL/INDICATOR/REVERSE/REFLECTORS	LEFT	20CM WITH PLUG
J3BARWMRCB	STOP/TAIL/INDICATOR/REVERSE/REFLECTORS	RIGHT	20CM WITH PLUG

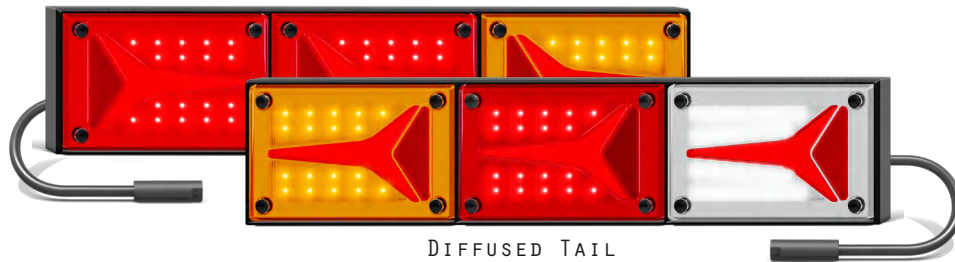

## 595 Series - SIZE 595MM X 130MM X 45MM

Part No	Function	Side	Cable
595BARRMLCSB	STOP/TAIL/INDICATOR/REFLECTORS	LEFT	40CM WITH PLUG
595BARRMRCB	STOP/TAIL/INDICATOR/REFLECTORS	RIGHT	40CM WITH PLUG
595BARWMLCSB	STOP/TAIL/INDICATOR/REVERSE/REFLECTORS	LEFT	40CM WITH PLUG
595BARWMRCB	STOP/TAIL/INDICATOR/REVERSE/REFLECTORS	RIGHT	40CM WITH PLUG

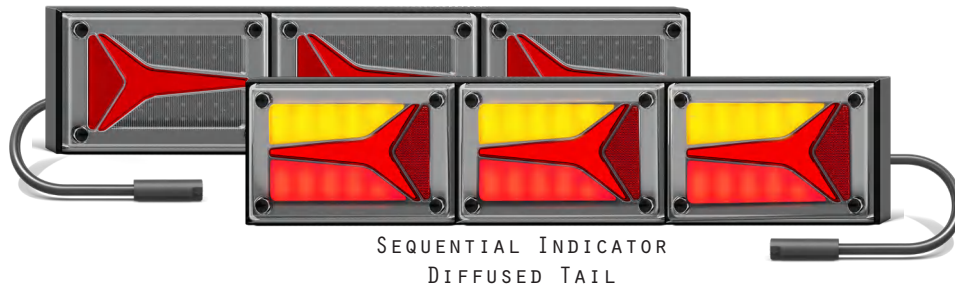

## 595 Series - SIZE 595MM X 130MM X 45MM

Part No	Function	Side	Cable
595STIM3LCSB	STOP/TAIL/INDICATOR/REFLECTORS	LEFT	40CM WITH PLUG
595STIM3RCB	STOP/TAIL/INDICATOR/REFLECTORS	RIGHT	40CM WITH PLUG

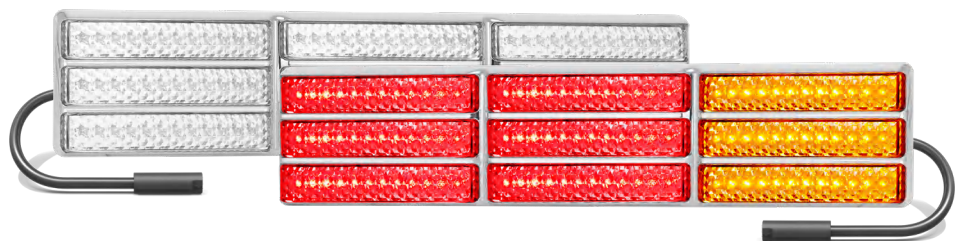

## J9 Series - SIZE 595MM X 130MM X 28MM

Part No	Function	Side	Cable
J9CCARRMLCSB	STOP/TAIL/INDICATOR	LEFT	20CM WITH PLUG
J9CCARRMRCB	STOP/TAIL/INDICATOR	RIGHT	20CM WITH PLUG

# 97 Series Category 5 Side Direction Indicator/Marker Lamps

Note: Visit our website, [www.ledautolmaps.com](http://www.ledautolmaps.com) for further specifications and mounting information.

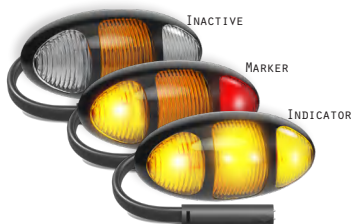

## Black Bezel - SIZE 99MM X 47MM X 28MM

Part No	Function	Cable
97ARIMCSB	SIDE MARKER/ CAT5 SIDE DIRECTION INDICATOR	40CM WITH PLUG

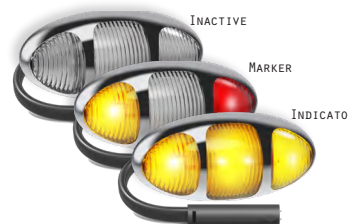

## Chrome Bezel - SIZE 99MM X 47MM X 28MM

Part No	Function	Cable
97CARIMCSB	SIDE MARKER/ CAT5 SIDE DIRECTION INDICATOR	40CM WITH PLUG



## Black Bezel - SIZE 99MM X 47MM X 28MM

Part No	Function	Cable
97AIMCSB	SIDE MARKER/ CAT5 SIDE DIRECTION INDICATOR	40CM WITH PLUG



## Chrome Bezel - SIZE 99MM X 47MM X 28MM

Part No	Function	Cable
97CAIMCSB	SIDE MARKER/ CAT5 SIDE DIRECTION INDICATOR	40CM WITH PLUG

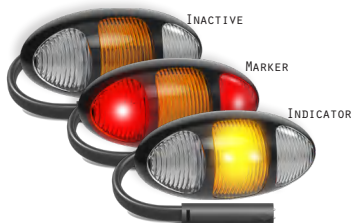

## Black Bezel - SIZE 99MM X 47MM X 28MM

Part No	Function	Cable
97RIMCSB	REAR END OUTLINE SUPPLEMENTARY INDICATOR**	40CM WITH PLUG

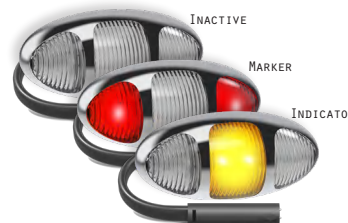

## Chrome Bezel - SIZE 99MM X 47MM X 28MM

Part No	Function	Cable
97CRIMCSB	REAR END OUTLINE SUPPLEMENTARY INDICATOR**	40CM WITH PLUG



## Black Bezel - SIZE 99MM X 47MM X 28MM

Part No	Function	Cable
97WIMCSB	FRONT END OUTLINE SUPPLEMENTARY INDICATOR**	40CM WITH PLUG



## Chrome Bezel - SIZE 99MM X 47MM X 28MM

Part No	Function	Cable
97CWIMCSB	FRONT END OUTLINE SUPPLEMENTARY INDICATOR**	40CM WITH PLUG

Note:

\*\* Supplementary Front and Rear Indicator is Non-ADR, to be used in conjunction with existing lamps



# Marker Lamps and Side Direction Indicator Lamps

Note: Visit our website, [www.ledautolamps.com](http://www.ledautolamps.com) for further specifications and mounting information.

**3M**



## 5025 Series - SIZE 50MM X 25MM X 21MM

Part No	Function	Cable
5025ARMCSB	AMBER/RED SIDE MARKER	20CM WITH PLUG
5025RMCBSB	REAR END OUTLINE MARKER	20CM WITH PLUG
5025AMCSB	SIDE DIRECTION SIDE MARKER	20CM WITH PLUG
5025WMCBSB	FRONT END OUTLINE MARKER	20CM WITH PLUG

## 58 Series - SIZE 58MM X 35MM X 21MM



Part No	Function	Cable
58ARMCSB	AMBER/RED SIDE MARKER	20CM WITH PLUG
58RMCBSB	REAR END OUTLINE MARKER	20CM WITH PLUG
58AMCSB	SIDE DIRECTION SIDE MARKER	20CM WITH PLUG
58WMCBSB	FRONT END OUTLINE MARKER	20CM WITH PLUG

**3M**



## 37 Series - SIZE 70MM X 35MM X 20MM

Part No	Function	Cable
37ARMCSB	AMBER/RED SIDE MARKER	20CM WITH PLUG
37RMCBSB	REAR END OUTLINE MARKER	20CM WITH PLUG
37AMCSB	SIDE DIRECTION SIDE MARKER	20CM WITH PLUG
37WMCBSB	FRONT END OUTLINE MARKER	20CM WITH PLUG

## 42 Series - SIZE 74MM X 38MM X 35MM



Part No	Function	Cable
42ARMCSB	AMBER/RED SIDE MARKER	20CM WITH PLUG
42RMCBSB	REAR END OUTLINE MARKER	20CM WITH PLUG
42AMCSB	SIDE DIRECTION SIDE MARKER	20CM WITH PLUG
42WMCBSB	FRONT END OUTLINE MARKER	20CM WITH PLUG

**3M**



## EU38 Series - SIZE 100MM X 38MM X 13MM

Part No	Function	Cable
EU38RMCBSB	REAR END OUTLINE MARKER/REFLECTOR	20CM WITH PLUG
EU38AMCSB	SIDE MARKER/ REFLECTOR	20CM WITH PLUG
EU38WMCBSB	FRONT END OUTLINE MARKER/REFLECTOR	20CM WITH PLUG

## 181 Series - SIZE 28MM ROUND X 5MM



Part No	Function	Cable
181RMCBSB	REAR END OUTLINE MARKER	20CM WITH PLUG
181AMCSB	SIDE MARKER	20CM WITH PLUG
181WMCBSB	FRONT END OUTLINE MARKER	20CM WITH PLUG

## Reverse Accessory Products

**Important Note;** When Reverse lamps are run as an accessory in the reverse system then the maximum power allowable is 60 watts in a 12 volt system or 120 watts in a 24 volt system. It is recommended the work lamps when used as a reverse light should be run from the blue wire/splitters, see page 23. The following table should be followed if Reverse Lamps are already used in the system and more are to be added.

### Additional Reverse Lamps Max Combined Output in Watts

No. Of Reverse Lamps	12 Volt System	24 Volt System
2	46 Watts	92 Watts
4	36 Watts	72 Watts
6	24 Watts	48 Watts



### 7312 Series - SIZE 73MM X 73MM X 31MM

Part No	Function	Cable
7312BMCSB	12 WATT REVERSE LAMP	20CM WITH PLUG



### 7512 Series - SIZE 75MM X 75MM X 30MM

Part No	Function	Cable
7512BMCSB	12 WATT REVERSE LAMP	20CM WITH PLUG



### Beepers - SIZE 100MM X 68MM X 41MM

Part No	Function	Cable
2PF200ETB	REVERSE BEEPER	20CM WITH PLUG
2PF200RAB	REVERSE BEEPER (DG)	20CM WITH PLUG



### Squawkers - SIZE 100MM X 68MM X 41MM

Part No	Function	Cable
2PF200SQB	REVERSE SQUAWKER	20CM WITH PLUG

## Rotating Beacon Accessory



### LRB130 Beacon

SIZE 130MM X 53MM

Part No	Cable
LRB130CSB	13CM WITH PLUG

USED WITH BLUE ACCESSORY WIRE SEE PAGE 23

## Licence Plate Lamps



### 60 Series

SIZE 60MM X 22MM X 22MM

Part No	Cable
60BLMCSB	20CM WITH PLUG



### 35 Series

SIZE 76MM X 42MM X 30MM

Part No	Cable
35BLMCSB	20CM WITH PLUG



### 6434 Series

SIZE 65MM X 30MM X 24MM

Part No	Cable
6434CWMCSB	20CM WITH PLUG
6434BWMCSB	20CM WITH PLUG



### 41 Series

SIZE 70MM X 42MM X 40MM

Part No	Cable
41BLMCSB	20CM WITH PLUG

## 7 Core Main Plugs and Covers

The 7CJB rear junction splitters are designed to split the 7 Core cable into a left and right side for rear lighting functions of Stop/Tail, Indicator and Reverse. The 7CJB also has left and right side 2 pin plugs to connect licence plate and marker lamps. The 7P3WB is a 7 Core cable splitter which gives you the ability to add another rear combination lamp and continue the harness cable before terminating with a final rear combination lamp assembly. The covers available for the plugs have been created for extra strength and engineered to a breaking strain of 25 kg. The connection cover is for secure fitment and completes Dangerous Goods Rating AS2809.



**Part No. Size**  
7CJB | 89MM X 61MM



**Part No. Size**  
CCJB | 186MM X 116MM



**Part No. Size**  
7P3WB | 94MM X 44MM



**Part No. Size**  
7PCB | 193MM X 50MM

## 7 Core Junction Splitter and Cover

The 7CJEB 7 Core Rear Junction Splitter Extension is used with the 7CJB, above to connect a 7 pin trailer base at the rear of the trailer. Its purpose is to connect another trailer to the existing harness system when using the 7CFTB rear trailer plug.

**Part No. Size**  
CMEB | 188MM X 178MM



**Part No. Size**  
7CJEB | 200MM

## 7 Core Trailer Base Front/Rear Termination

Heavy Duty, EBS, and 24 Volt Sockets available, see Page 24-25 for more information.



FRONT OF TRAILER

**Part No. Size**  
7CMTB | 200MM WITH PLUG  
12 VOLT



REAR OF TRAILER

**Part No. Size**  
7CFTB | 200MM WITH PLUG  
24 VOLT

## Marker Lamp Splitters

Defined by its brown colour, the Marker lamp splitters split from the 7 Core cable and power the marker lamps. The 7CMFB has dual splitters at a right angle to the 7 Core cable. The 7CFFB also has dual splitters but runs parallel to the 7 Core cable. The 7CFB is a single splitter that runs parallel to the 7 Core cable. The covers for the plugs have been created for extra strength and engineered to a breaking strain of 25kg. The connection cover is for secure fitment and completes Dangerous Goods Rating AS2809.

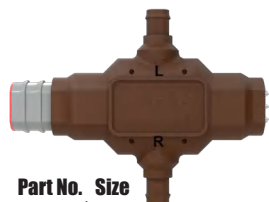

DUAL MARKER LAMP SPLITTER

**Part No. Size**  
7CMFB | 78MM X 60MM

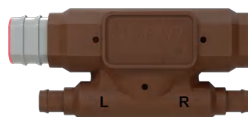

DUAL MARKER LAMP SPLITTER

**Part No. Size**  
7CFFB | 78MM X 37MM



MARKER LAMP SPLITTER

**Part No. Size**  
7CFB | 78MM X 37MM



SPLITTER COVER

**Part No. Size**  
CMAB | 175MM X 128MM



SPLITTER COVER

**Part No. Size**  
CMMB | 177MM X 44MM



SPLITTER COVER

**Part No. Size**  
CMBB | 177MM X 44MM

## 2 Core Splitters

The 2 Core splitters are used to split the 2 Core cable and powers Marker Lamps, Indicator (2 Core) lamps, Reverse lamps and Accessories. The plugs we have designed are 100% water-resistant, with a sealing lip that will not allow water ingress. The cover for the plugs have been created for extra strength and engineered to a breaking strain of 15kg. The connection covers ensures a secure fitment and completes Dangerous Goods Rating AS2809.



2 CORE/3 WAY SPLITTER

**Part No. Size**  
2P3WB | 62MM X 28MM



2 CORE/4 WAY SPLITTER

**Part No. Size**  
2P4WB | 62MM X 28MM



2P3WB SPLITTER COVER

**Part No. Size**  
2P3CB | 125MM X 35MM

## Indicator Lamp Splitters

Defined by its Yellow colour, the Indicator lamp splitters split from the 7 Core cable and power both the left and right-hand side indicator lamps. The 7CMIB has dual splitters at a right angle to the 7 Core cable. The 7CIRLB also has dual splitters but runs parallel to the 7 Core cable. The 7CILB and the 7CIRB are single splitters parallel with the 7 Core cable used for left-hand and right-hand indicators and defined by their colours Yellow for left and Green for right. The covers for the plugs have been created for extra strength and engineered to a breaking strain of 25kg. The connection cover is for secure fitment and completes Dangerous Goods Rating AS2809.



LEFT & RIGHT INDICATOR

**Part No. Size**  
7CMIB | 78MM x 60MM

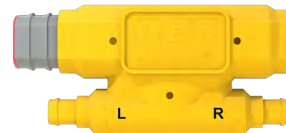

LEFT & RIGHT INDICATOR

**Part No. Size**  
7CIRLB | 78MM x 37MM

LEFT INDICATOR

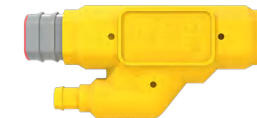

**Part No. Size**  
7CILB | 78MM x 37MM

RIGHT INDICATOR



**Part No. Size**  
7CIRB | 78MM x 37MM



SPLITTER COVER

**Part No. Size**  
CMAB | 175MM x 128MM



SPLITTER COVER

**Part No. Size**  
CMMB | 177MM x 44MM



SPLITTER COVER

**Part No. Size**  
CMBB | 177MM x 44MM

## Dual Function Marker/Indicator Splitters

Defined by its Yellow colour, the Dual function Marker/Indicator lamp splitter split from the 7 Core cable and power both the left and right-hand side Indicator/Marker lamps. The 7CILR3B has dual splitters at a right angle to the 7 Core cable. The 3P3IMB is a plug that splits one cable into two, and this allows the fitter to add as many combination Indicator/Marker lamps as required. All connectors have covers available for secure fitment of the cables ensuring Dangerous Goods Rating AS2809.



COMBINATION LEFT & RIGHT INDICATOR

**Part No. Size**  
7CILR3B | 78MM x 37MM



SPLITTER COVER

**Part No. Size**  
CMMB | 177MM x 44MM



3 CORE/3 WAY INDICATOR SPLITTER

**Part No. Size**  
3P3IMB | 62MM x 28MM



SPLITTER COVER

**Part No. Size**  
2P3CB | 125MM x 35MM

## Reverse Lamp Splitters

Defined by its black colour, the Reverse lamp splitters split from the 7 Core cable and power the reverse lamps and reverse beeper. The 7CRRB has dual splitters that run parallel to the 7 Core cable. The 7CRB is a single splitter that runs parallel to the 7 Core cable. The 2P3WB is a plug that splits one cable into two, allowing the fitter to add additional Reverse lamps. The cover for the plugs, created are engineered for extra strength to a breaking strain of 15kg for 2 Core and 25kg for 7 Core. The connection cover is for secure fitment and completes Dangerous Goods Rating AS2809.



DUAL REVERSE LAMP SPLITTER

**Part No. Size**  
7CRRB | 78MM x 37MM



REVERSE LAMP SPLITTER

**Part No. Size**  
7CRB | 78MM x 37MM



2 CORE/3 WAY SPLITTER

**Part No. Size**  
2P3WB | 62MM x 28MM



**Part No. Size**  
CMMB | 177MM x 44MM



**Part No. Size**  
CMBB | 177MM x 44MM



**Part No. Size**  
2P3CB | 125MM x 35MM

## Separate Stop/Tail Lamp Compatible with 3 Core Stop/Tail Plugs and Cables

The heavy-duty truck harness system has provisions for a separate stop/tail lamp. Plug in the stop/tail adapter, plug 7CSTB into the harness system, then run a 3 Core (3PMF) cable to connect a stop/tail lamp. If you require a second stop/tail lamp, then add the 3 Core splitter 3P3WB for an extra cable to connect the lamp. All connectors have covers available, ensuring Dangerous Goods Rating AS2809 and secure fitment with a breaking strain of 15kg for the cables.



BRAKE CONTROL LAMP SPLITTER

**Part No. Size**  
7CSTB | 78MM x 37MM



**Part No. Size**  
CMMB | 177MM x 44MM



3 CORE/3 WAY SPLITTER

**Part No. Size**  
3P3WB | 62MM x 28MM



**Part No. Size**  
2P3CB | 125MM x 35MM

## Brake Control or Accessory Splitter

Defined by its blue colour the 7CMBB has dual splitters at right angle to the 7 Core cable. The 7CBBB has dual splitters that run parallel with the 7 Core cable. The 7CBB plug is a single splitter that runs parallel with the 7 Core cable. These splitters power the brake control or any accessory when brake control is not required. The covers for the plugs have been created for extra strength and engineered to a breaking strain of 25kg. The connection cover is for secure fitment and completes Dangerous Goods Rating AS2809.



DUAL BRAKE CONTROL  
OR ACCESSORY LAMP  
SPLITTER

**Part No. Size**  
7CMBB | 78MM X 60MM



DUAL BRAKE CONTROL  
OR ACCESSORY LAMP  
SPLITTER

**Part No. Size**  
7CBBB | 78MM X 37MM



BRAKE CONTROL OR  
ACCESSORY LAMP  
SPLITTER

**Part No. Size**  
7CBB | 78MM X 37MM



**Part No. Size**  
CMAB | 175MM X 128MM



**Part No. Size**  
CMBB | 177MM X 44MM



**Part No. Size**  
CMBB | 177MM X 44MM

## Main Cable 7 Core Splitters

All assembly plugs are colour coded to its specific function. Example - The Brown plug is for Marker Lamps. When requiring a marker lamp, add a brown plug in the harness line. The Yellow (LHS) or Green (RHS) plug is for Side Direction Indicator Lamps. When requiring a Side Direction Indicator lamp, add a yellow or green plug whether left or right hand side in the harness line.

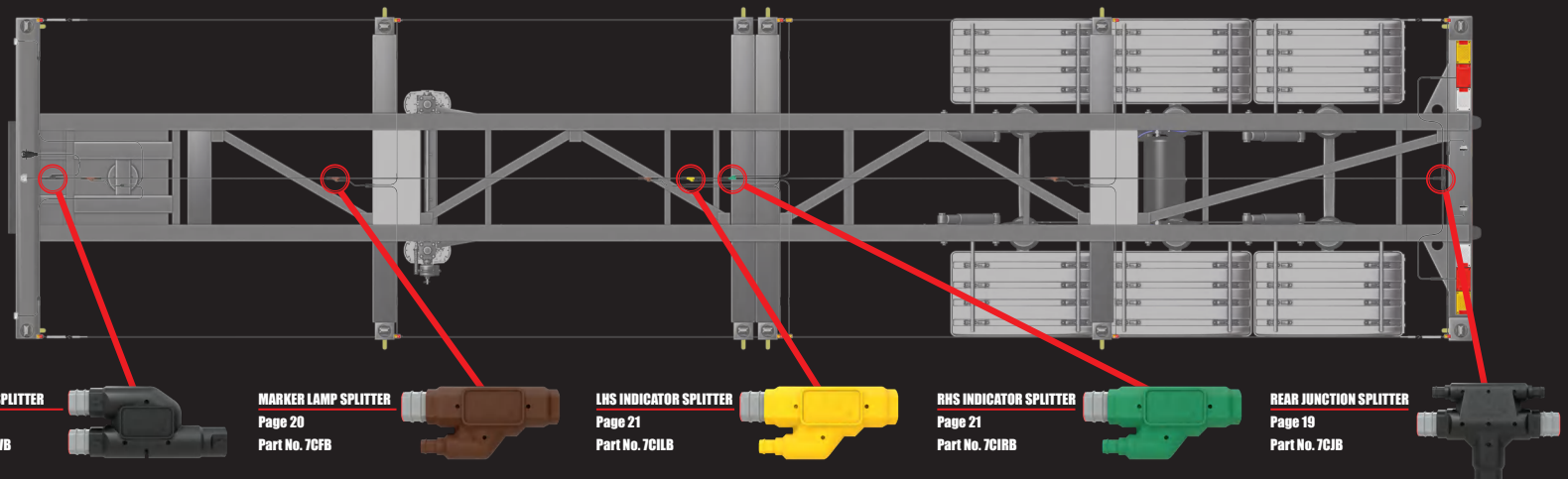

**MAIN CABLE SPLITTER**  
Page 19  
Part No. 7P3WB

**MARKER LAMP SPLITTER**  
Page 20  
Part No. 7CFB

**LHS INDICATOR SPLITTER**  
Page 21  
Part No. 7C1LB

**RHS INDICATOR SPLITTER**  
Page 21  
Part No. 7C1RB

**REAR JUNCTION SPLITTER**  
Page 19  
Part No. 7C1B

## Standard/Heavy Duty Sockets, Plugs and Suzi Coils

These 7 pin connectors and Suzi coils are for electrical connection between a vehicle and a trailer. Both voltages available, 12V - ISO 1724 and 24V - ISO 1185/DIN 72579. The plugs and connectors either use corrosion-resistant aluminium or plastic materials with Nickel-plated Brass contacts.



ISO/DIN  
1724

**Part No.** 7PSOCKETSDB  
**Description** 7 PIN ALLOY STANDARD DUTY SOCKET, 12 VOLT



ISO/DIN  
1724

**Part No.** 7PPLUGSDB  
**Description** 7 PIN ALLOY STANDARD DUTY PLUG, 12 VOLT

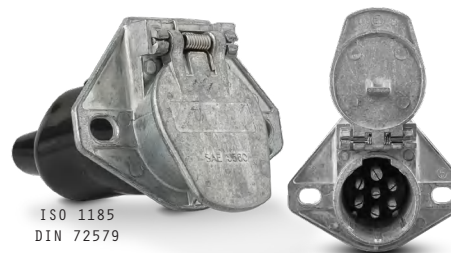

ISO 1185  
DIN 72579

**Part No.** 7PSOCKETHD24B  
**Description** 7 PIN ALLOY HEAVY DUTY SOCKET, 24 VOLT



ISO 1185  
DIN 72579

**Part No.** 7PPLUGHD24B  
**Description** 7 PIN ALLOY HEAVY DUTY PLUG, 24 VOLT

**Part No.** 7PSUZI1212  
**Description** 7 PIN SUZI COIL, 60MM COIL DIAMETER, SHORT TAIL ENDS, TOTAL EXTENDED LENGTH 4.5M, 12 VOLT.



ISO/DIN  
1724

**Part No.** 7PSUZI1M1212  
**Description** 7 PIN SUZI COIL, 60MM COIL DIAMETER, 1M LONG TAIL END, TOTAL EXTENDED LENGTH 5.6M, 12 VOLT.



ISO/DIN  
1724

**Part No.** 7PSUZI1224  
**Description** 7 PIN SUZI COIL, 60MM COIL DIAMETER, SHORT TAIL ENDS, TOTAL EXTENDED LENGTH 4.5M, 12-24 VOLT.



ISO 1185  
DIN 72579

**Part No.** 7PSUZI1M1224  
**Description** 7 PIN SUZI COIL, 60MM COIL DIAMETER, 1M LONG TAIL END, TOTAL EXTENDED LENGTH 5.6M, 12-24 VOLT.



ISO 1185  
DIN 72579

**Part No.** 7PSUZI2424  
**Description** 7 PIN SUZI COIL, 60MM COIL DIAMETER, SHORT TAIL ENDS, TOTAL EXTENDED LENGTH 4.5M, 24 VOLT.



ISO 1185  
DIN 72579

**Part No.** 7PSUZI1M2424  
**Description** 7 PIN SUZI COIL, 60MM COIL DIAMETER, 1M LONG TAIL END, TOTAL EXTENDED LENGTH 5.6M, 24 VOLT.



ISO 1185  
DIN 72579



## ABS/EBS Sockets, Plugs and Suzi Coils

These connectors are specific for the ABS/EBS braking system between a truck, trailer or semitrailer, both for 12V and 24V systems. The ABS/EBS plugs, connectors conform to ISO/DIN 7638, and the materials used conform to ADR/GGVs norm requirements for vehicles transporting hazardous goods. The plugs are connected to the sockets with a steel bracket to avoid accidental disconnection. Mechanical resistance and water tightness guarantee an efficient and reliable electrical connection.

ABS/EBS  
ISO/DIN 7638



**Part No.** 7PSOCKETEBS24B  
**Description** 7 PIN EBS SOCKET, 24 VOLT

ABS/EBS  
ISO/DIN 7638

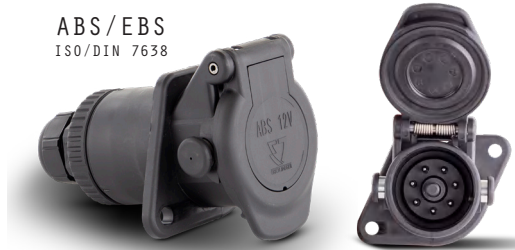

**Part No.** 7PSOCKETEBS12B  
**Description** 7 PIN EBS SOCKET, 12 VOLT

ABS/EBS  
ISO/DIN 7638



**Part No.** 7PPLUGESMB  
**Description** 7 PIN EBS PLUG, 12/24V

ABS/EBS  
ISO/DIN 7638



**Part No.** 7PSUZIEBSMB  
**Description** 7 PIN SUZI COIL CONNECTORS WITH 300MM EXTENDED LENGTH FROM SUZI COIL ON EACH SIDE TOTAL EXTENDED LENGTH 4.5M, 12/24 VOLT

ABS/EBS  
ISO/DIN 7638



**Part No.** 7PSUZIEBSM1B  
**Description** 7 PIN SUZI COIL CONNECTORS WITH 300MM AND 1M EXTENDED LENGTH FROM SUZI COIL. TOTAL EXTENDED LENGTH 5.6M, 12/24 VOLT

# Standard Type Skel or Flat Top Trailer



SKEL TRAILER  
SCHEMATIC

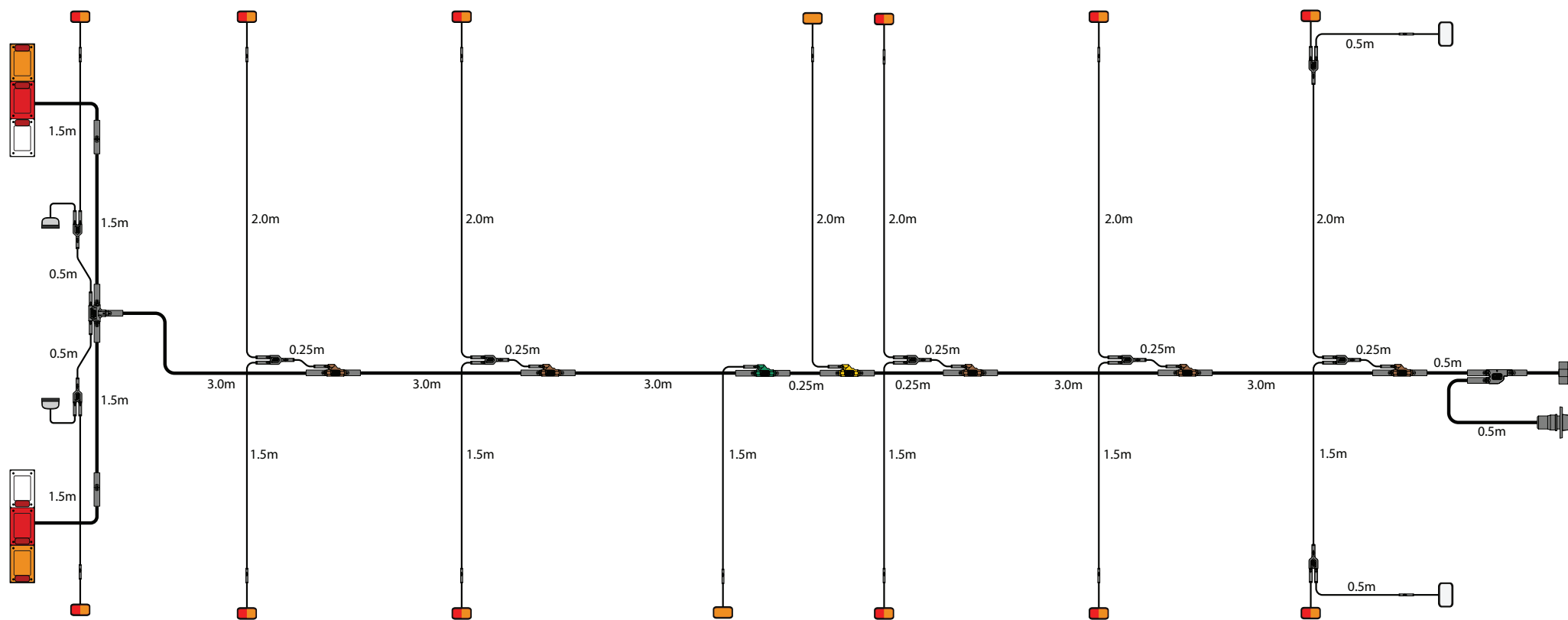

FLAT BED  
SCHEMATIC

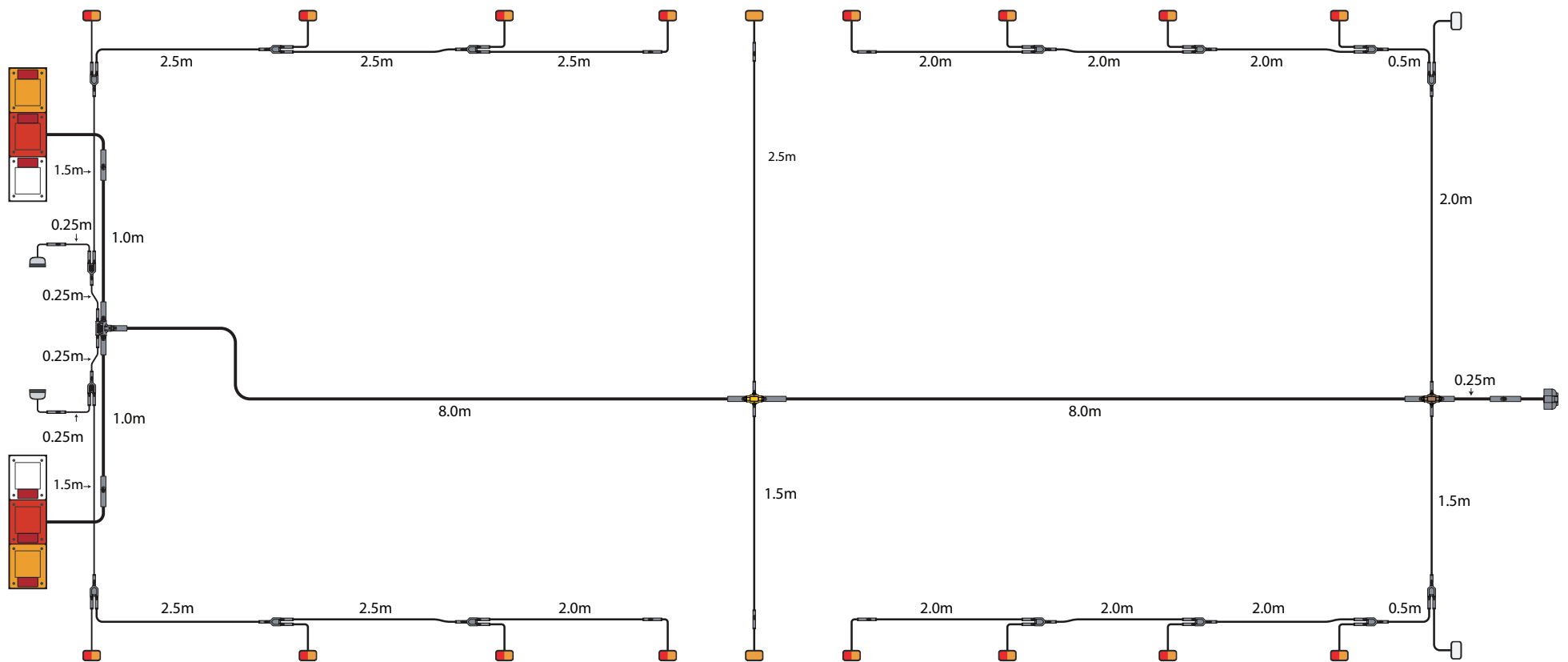

# Refrigerator Trailer Semi, A Lead, Box

REFRIGERATOR SEMI  
SCHEMATIC

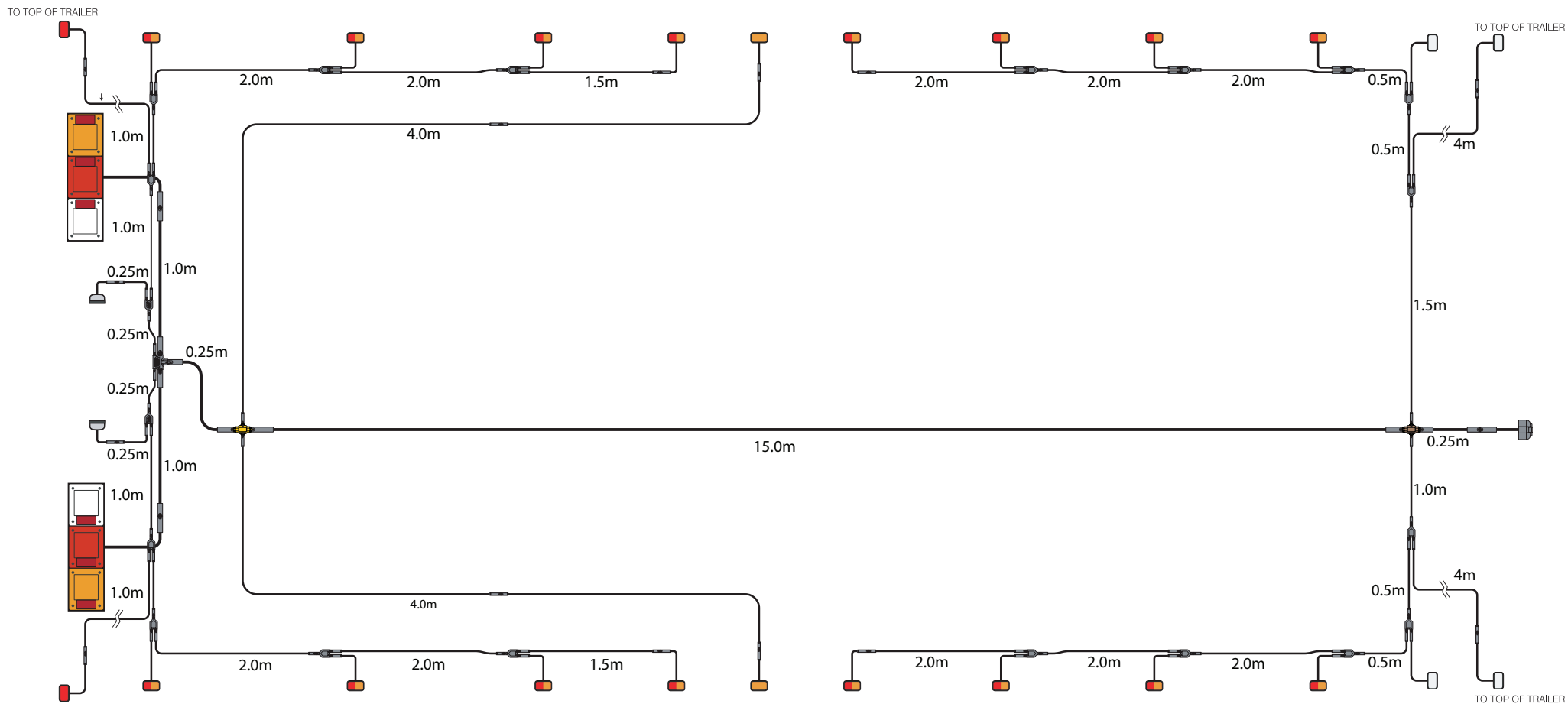

A-LEAD TRAILER  
SCHEMATIC

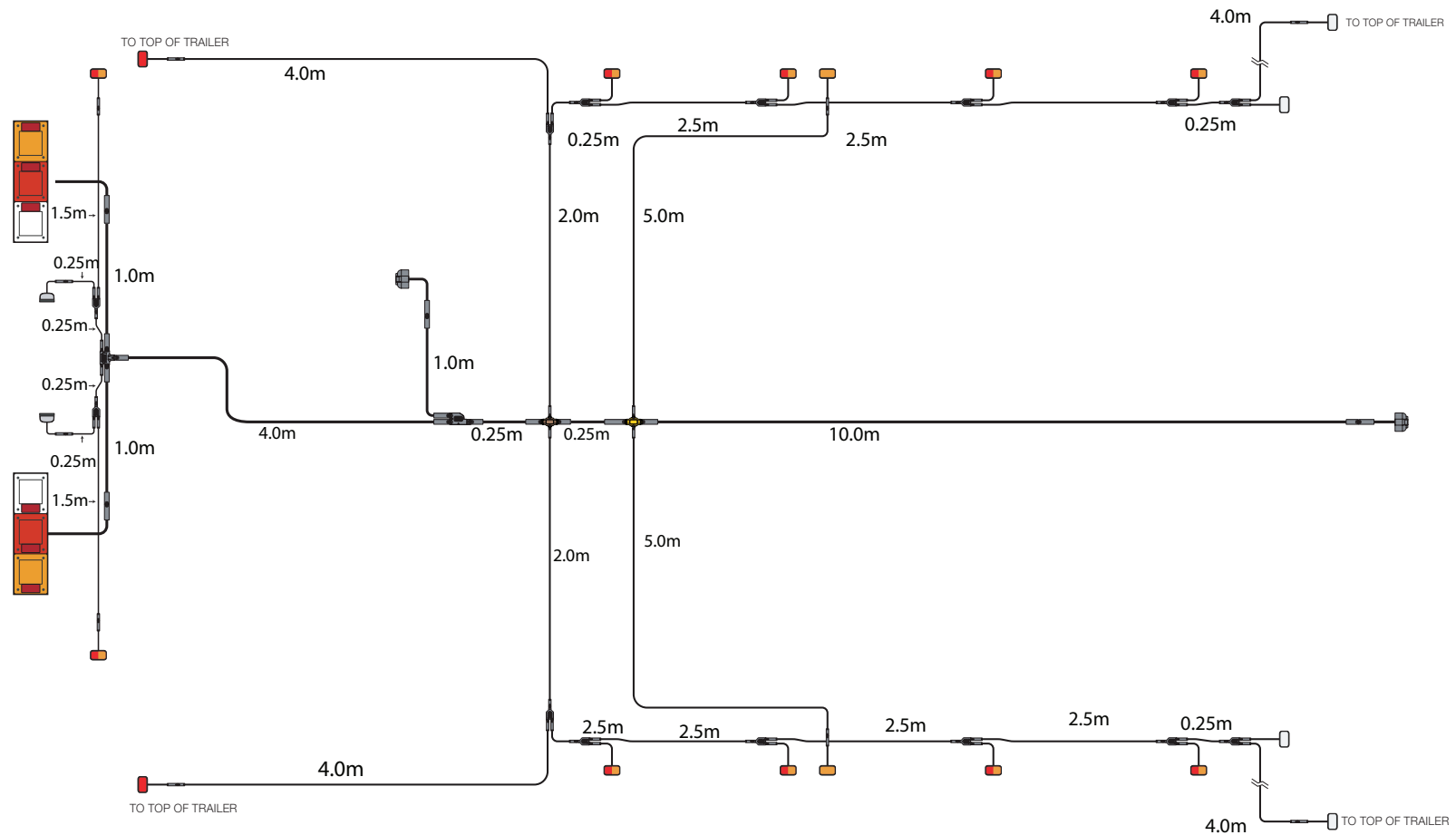

# Curtainsider

CURTAINSIDER  
SEMI SCHEMATIC

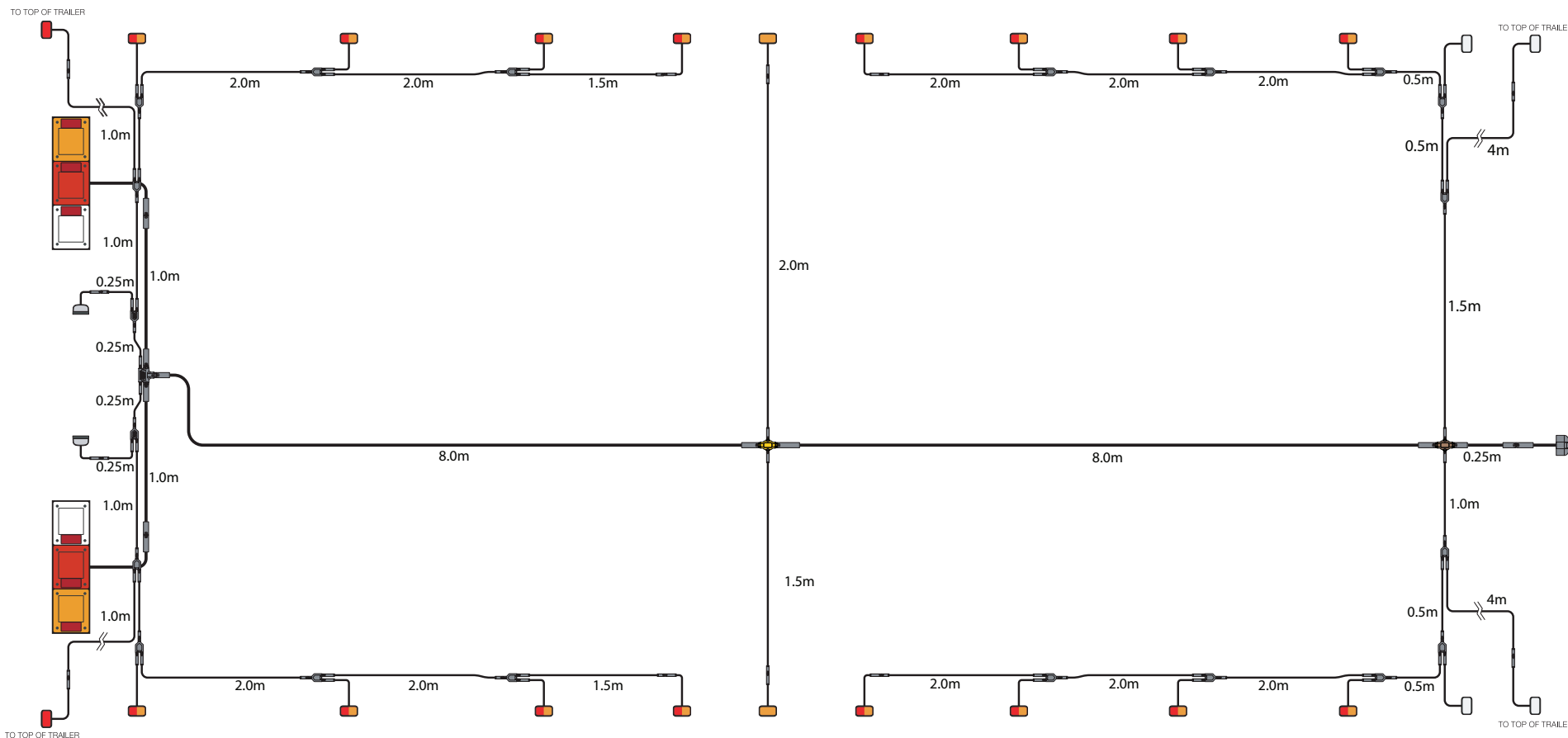

CURTAINSIDER  
DROP-DECK  
SCHEMATIC

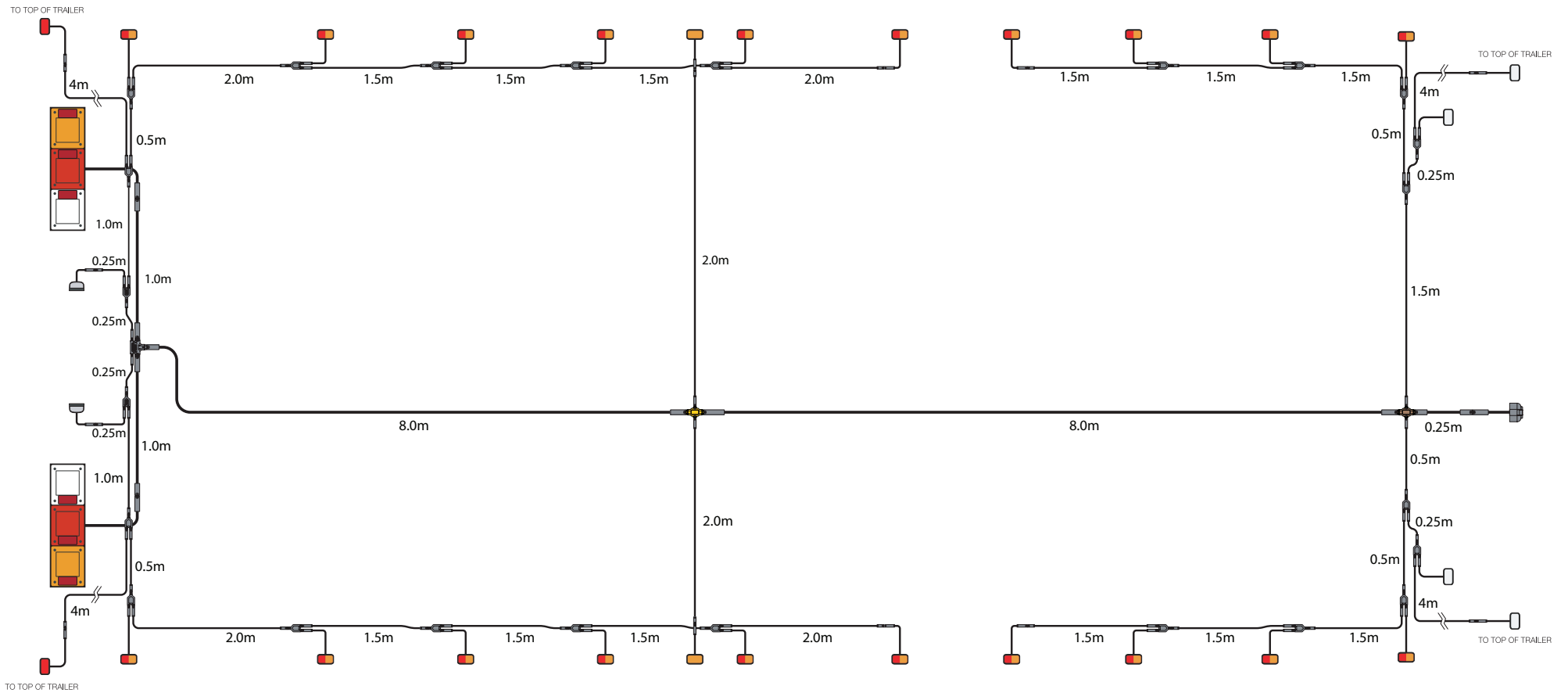

# Curtainsider with Dual Function Marker/Indicator

CURTAINSIDER SEMI SCHEMATIC

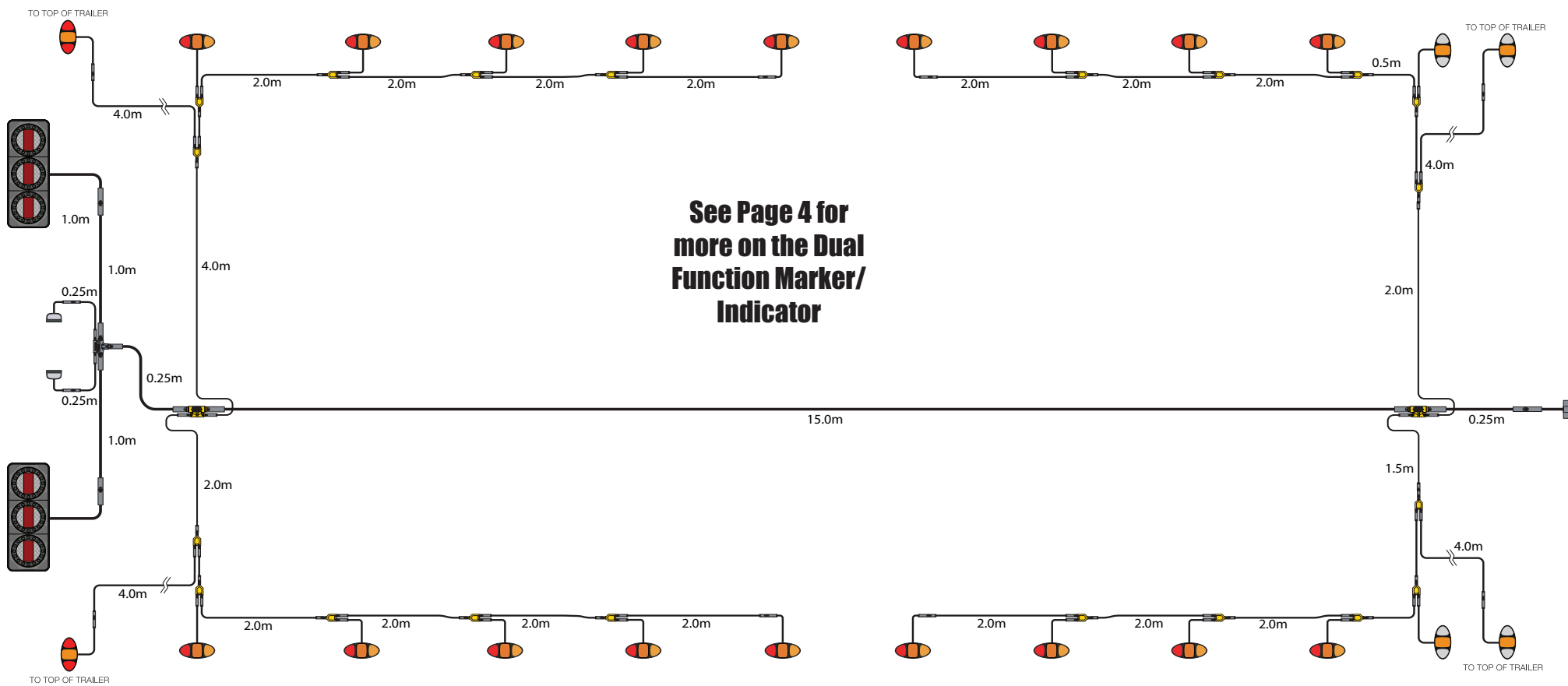



CURTAINSIDER  
RIGID  
SCHEMATIC

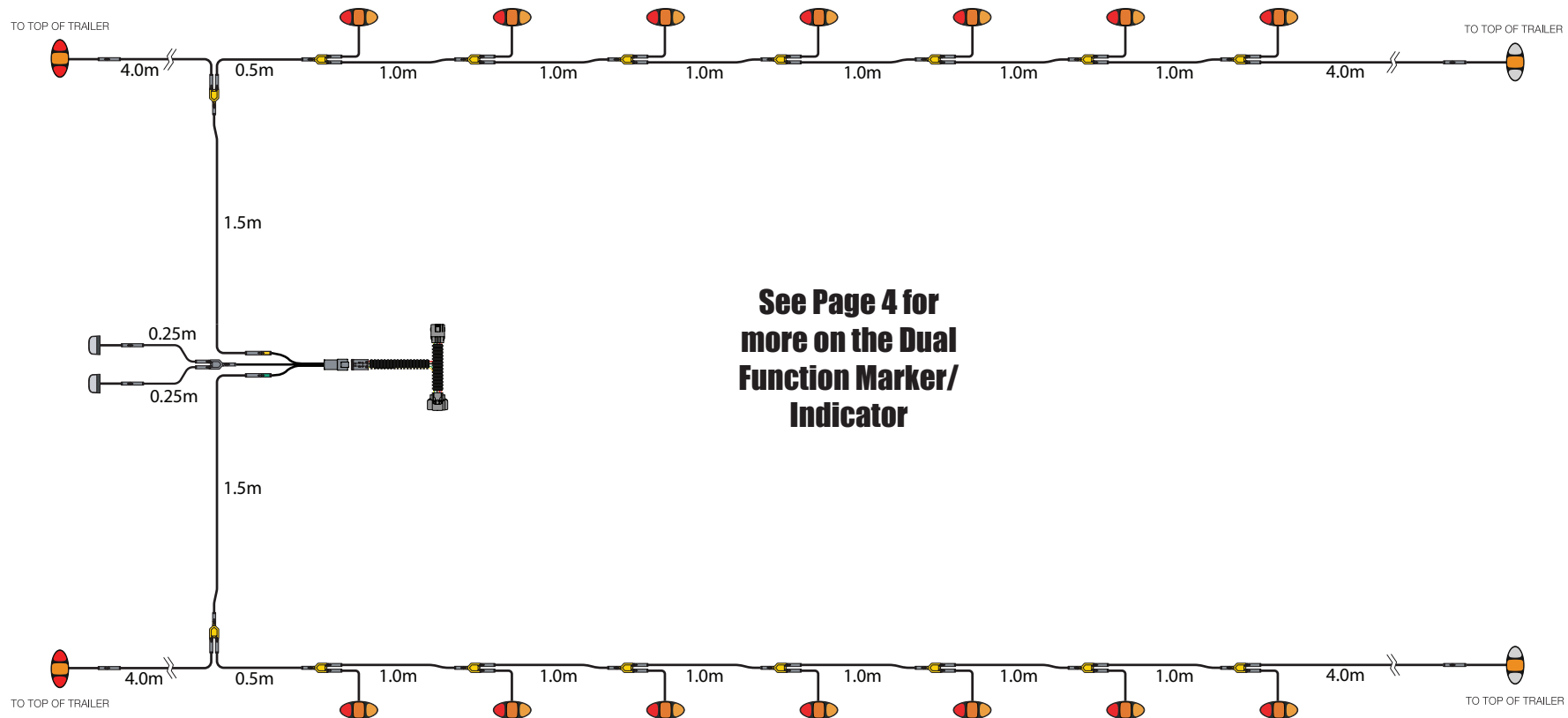

**See Page 4 for  
more on the Dual  
Function Marker/  
Indicator**

# A&B Coupling Dolly/Tag



LEAD/MIDDLE  
CURTAINSIDER

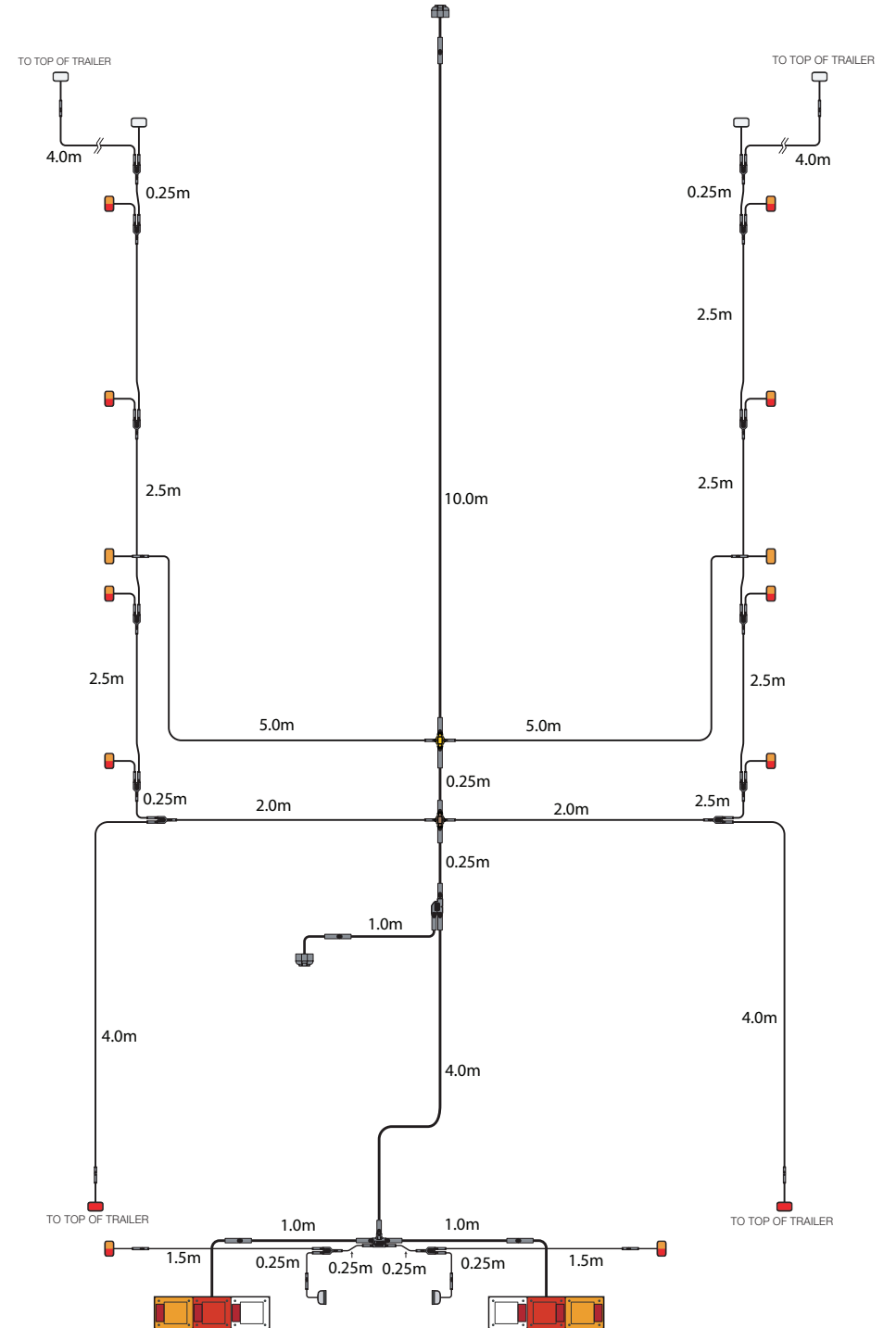



DOLLY SCHEMATIC

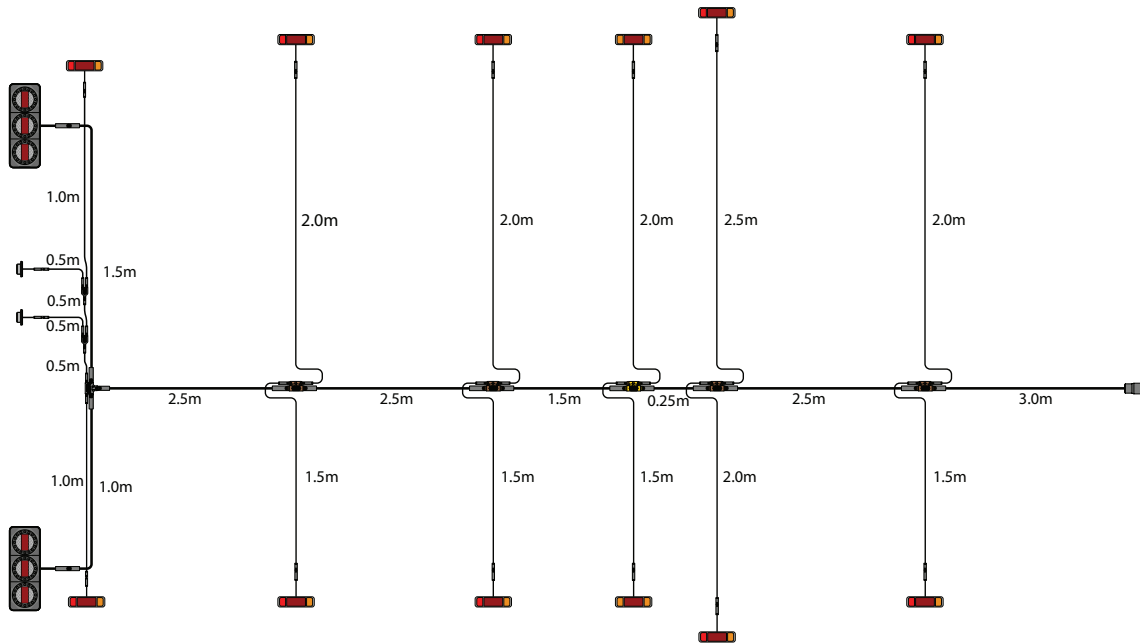
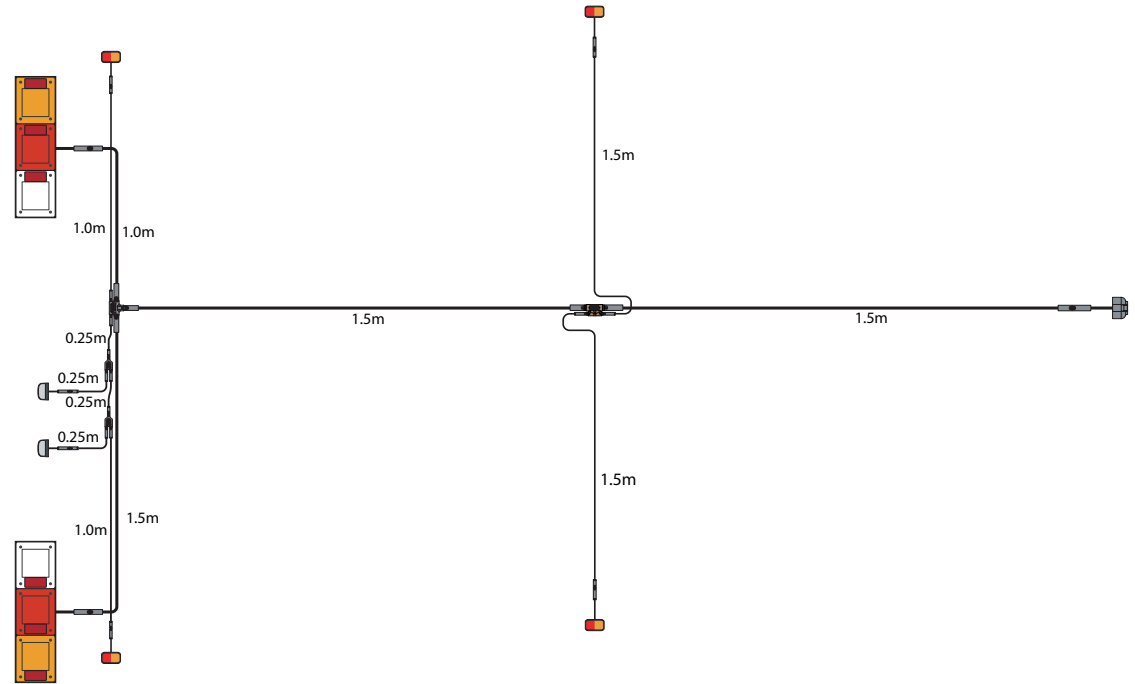

TRI AXLE TAG TRAILER

# Standard Type Fuel Liquids Rigid/Tanker Trailer



RIGID TANKER  
SCHEMATIC

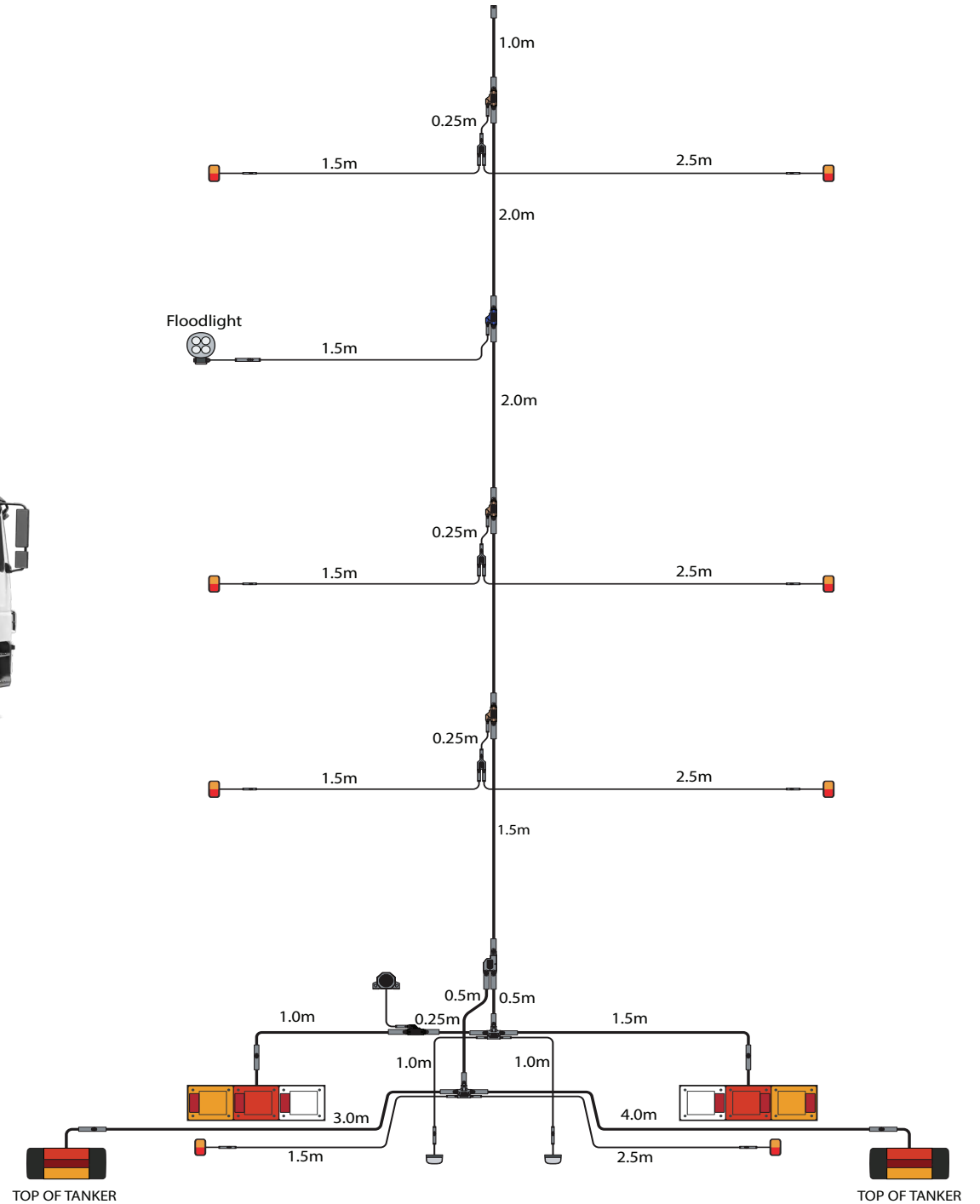



TANKER TRAILER  
SCHEMATIC

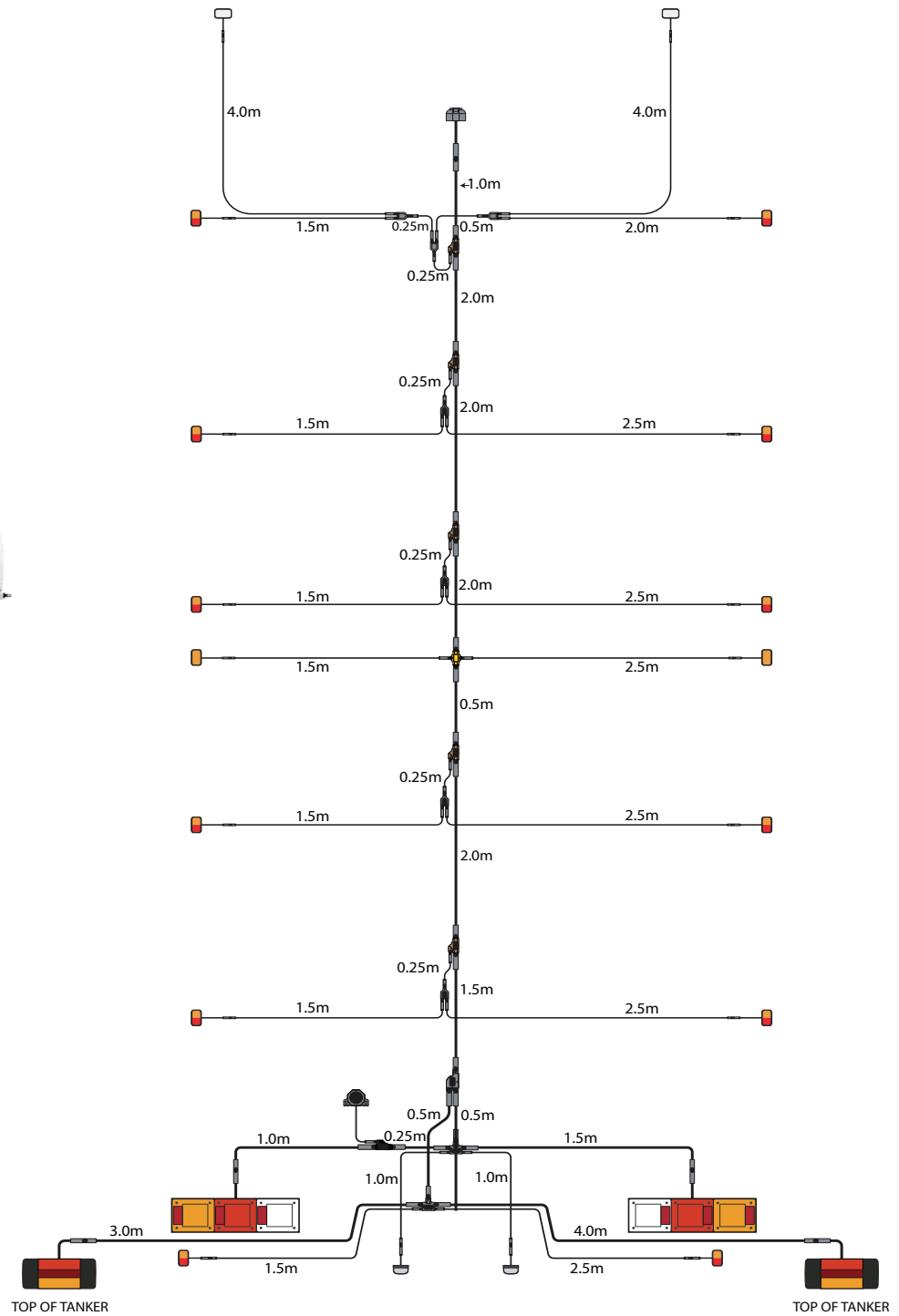

# Rigid Tipper Dog/Pig Trailers



RIGID TIPPER  
SCHEMATIC

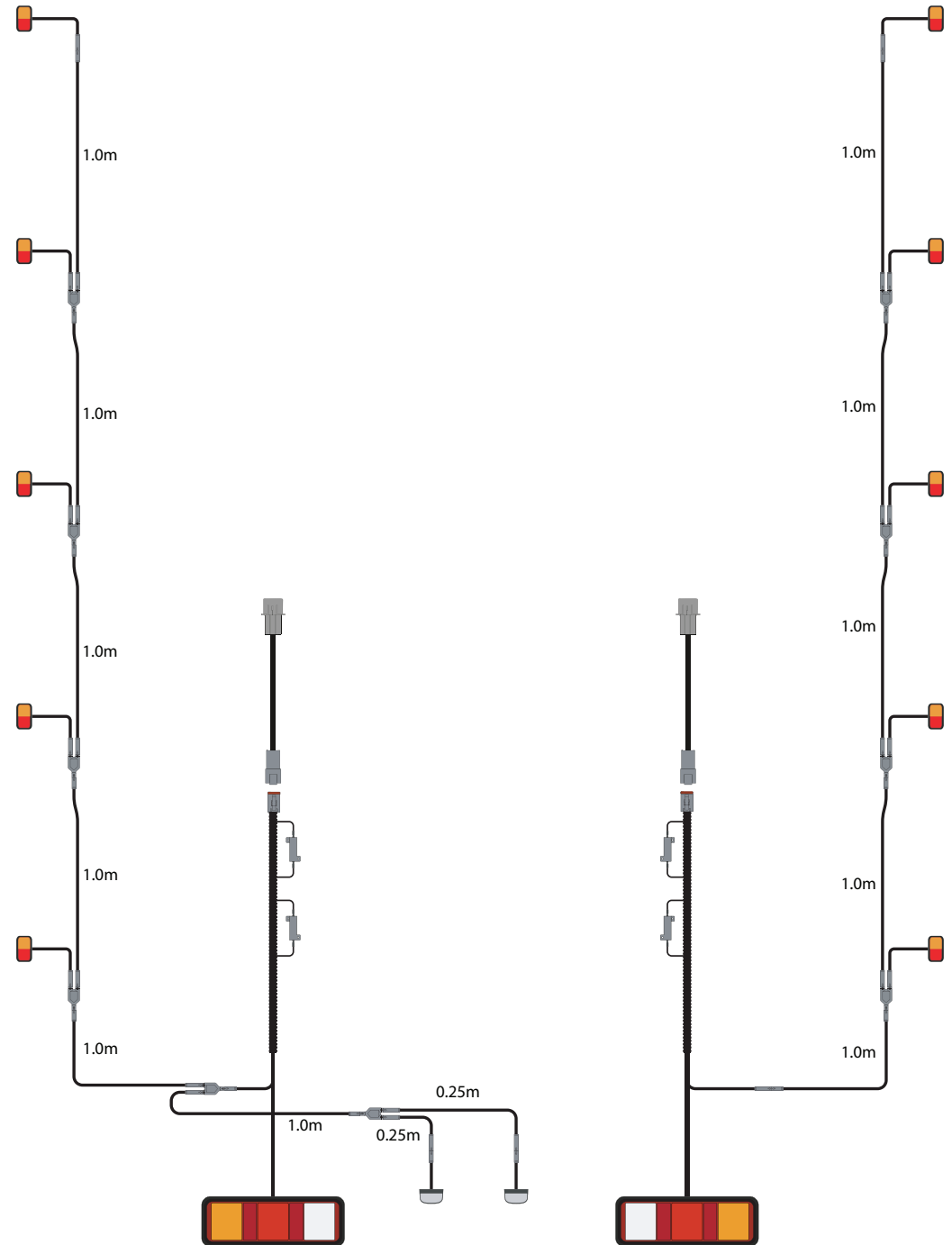



3 AXLE DOG TIPPER  
SCHEMATIC

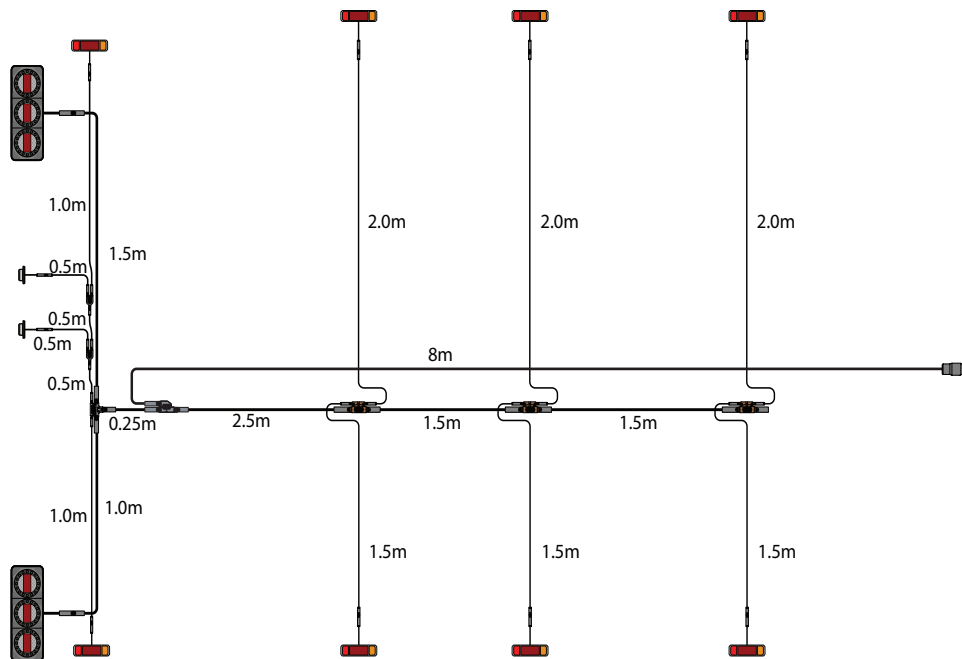
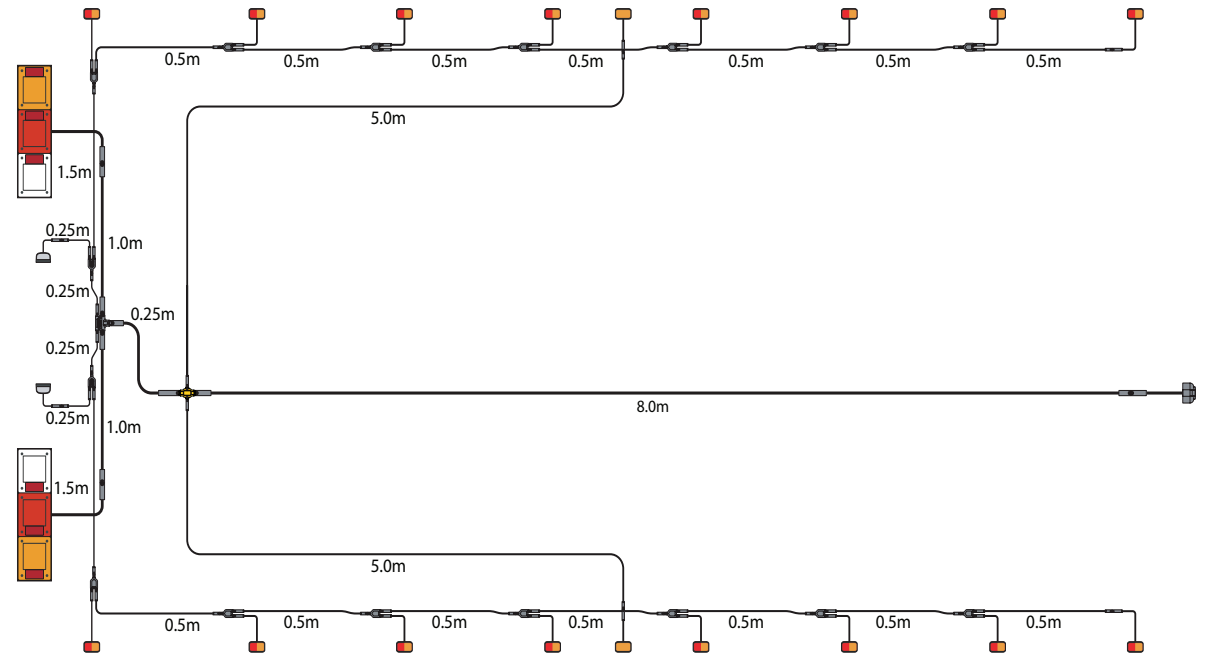

3 AXLE PIG TIPPER  
SCHEMATIC

# Rigid Tilt Tray Curtainsider/Tray

TILT TRAY  
SCHEMATIC

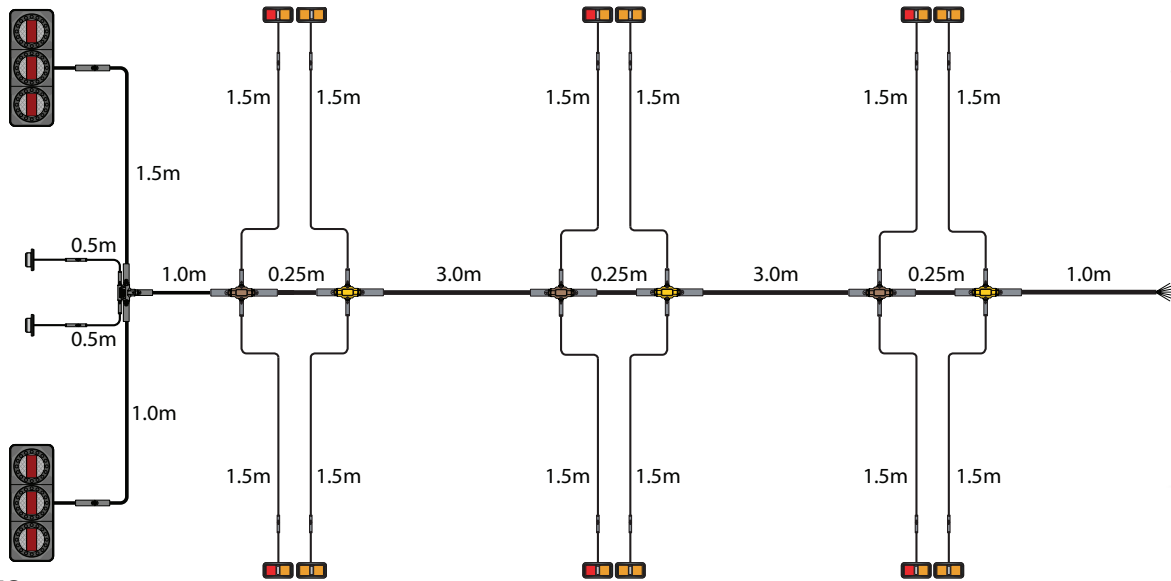
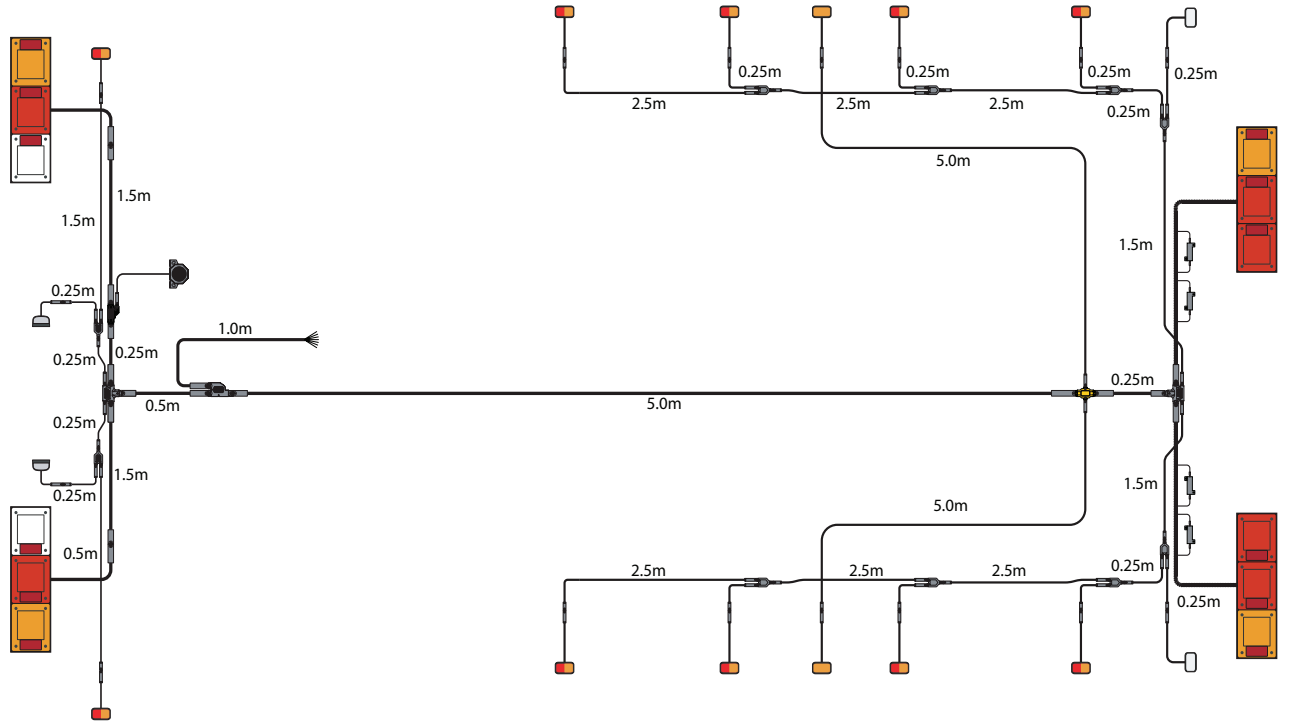

TRAY TRUCK  
SCHEMATIC





CURTAINSIDER  
SCHEMATIC

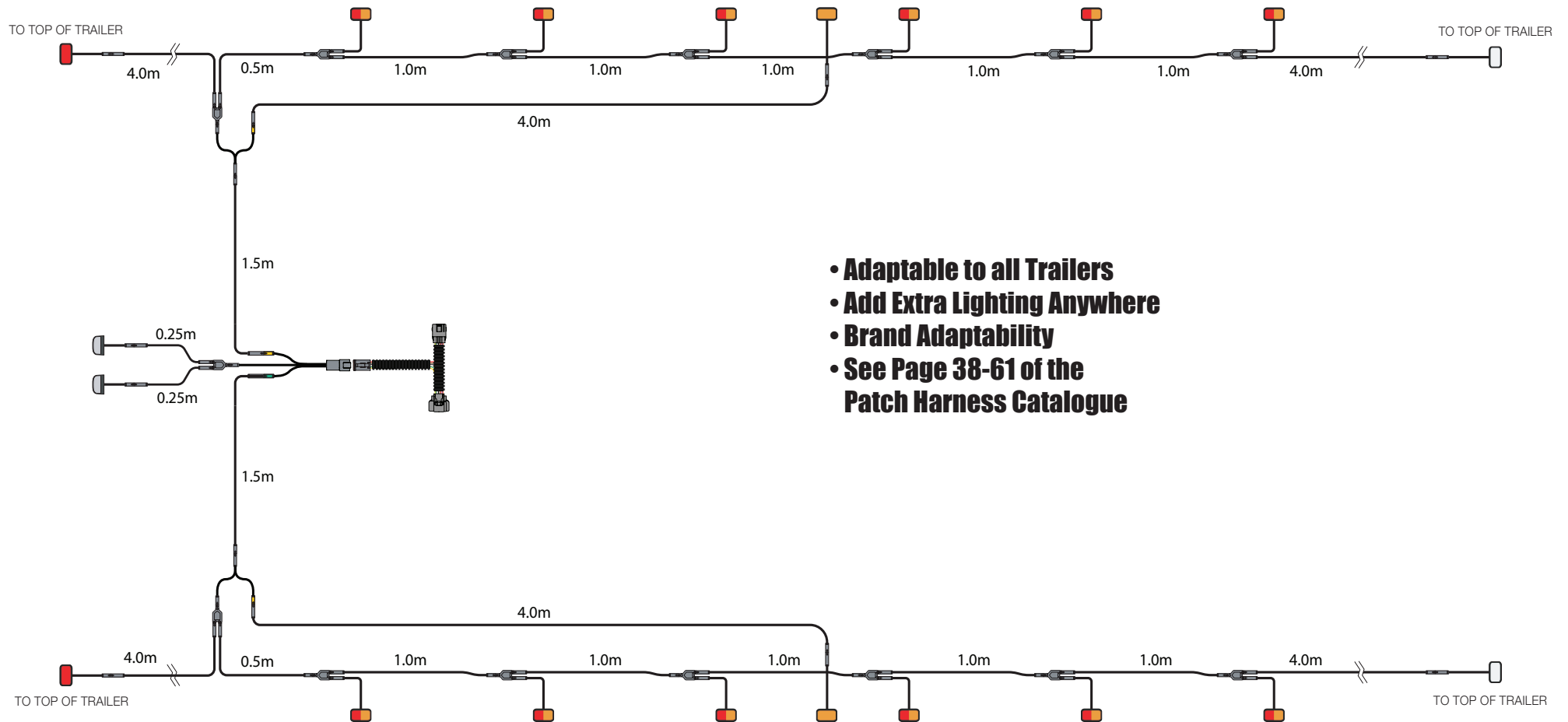

- **Adaptable to all Trailers**
- **Add Extra Lighting Anywhere**
- **Brand Adaptability**
- **See Page 38-61 of the Patch Harness Catalogue**

# Side Lifters and Drop Decks



SIDE LIFTER  
SCHEMATIC

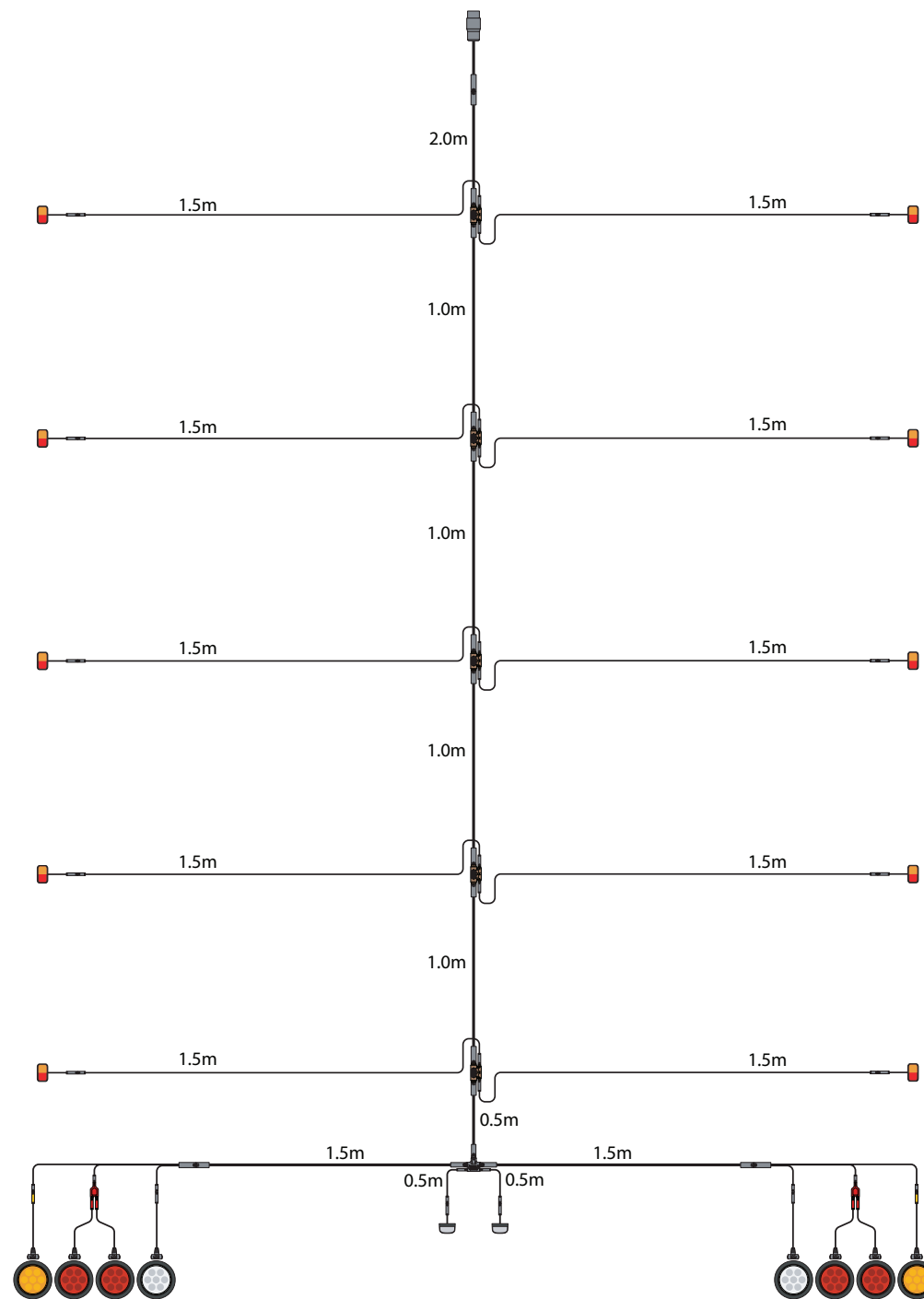



DROP DECK  
SCHEMATIC

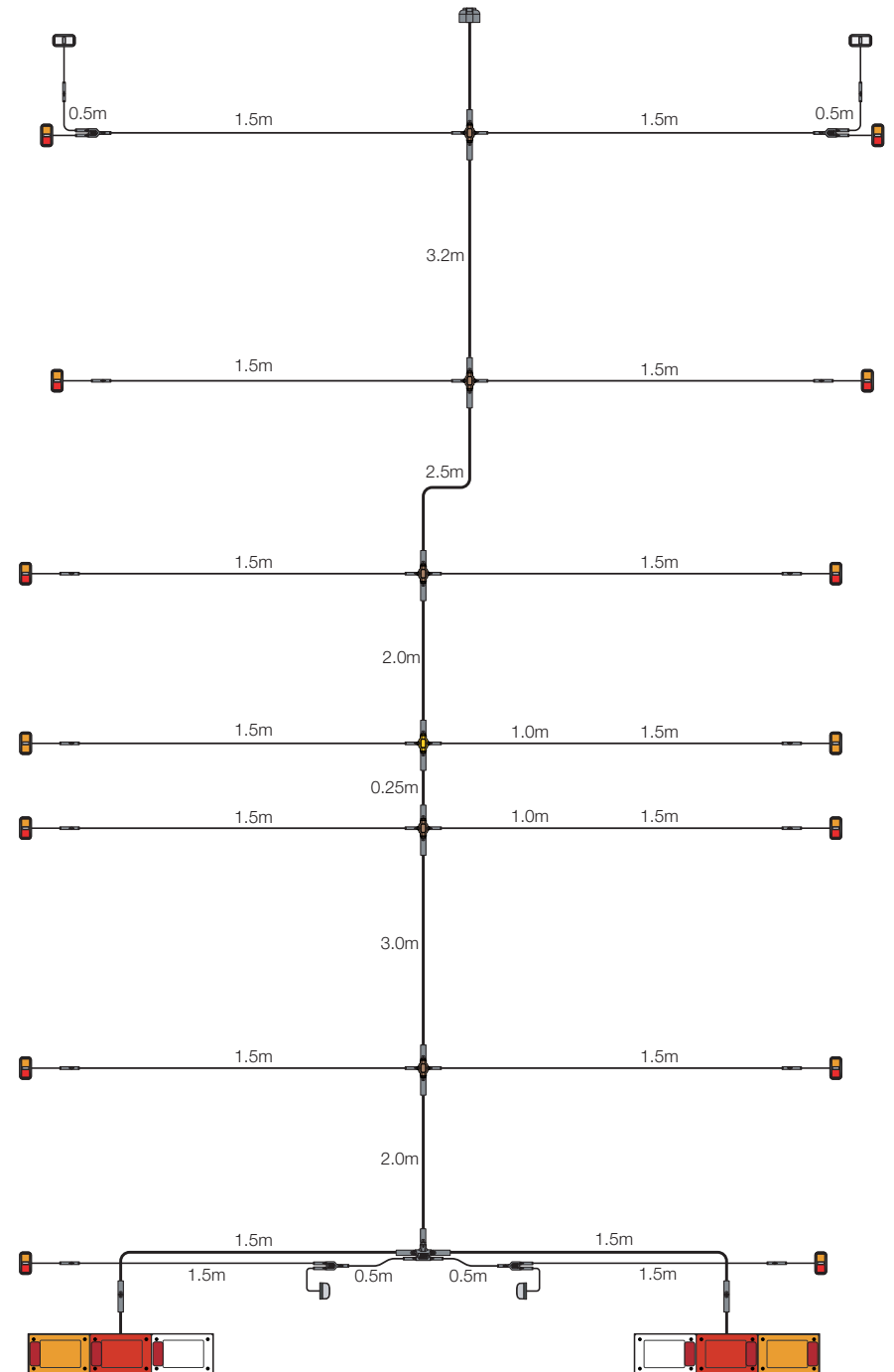

# Road Train Adaptability to ADR 63/00 Vehicle Standards



Trailer compliance for use in road train is made possible with our 7CRT range of Road Train Cables. We use a 7 Core (6mm) RTC cable that's Australian made, conforms to applicable standards and is professionally adapted to our cable harness and lighting system. Both options available have a total extended length of 5m, 13m, 14.5, 15.5m and 16m respectively and use high-quality 12V, ISO 1724 and 24V, ISO 1185/DIN 7579 corrosion-resistant aluminium 7 Pin sockets. The standard 7CRT also offers 2 Core and 7 Core harness plugs, whilst the 7CRT.RT is suited to retractable skeletal trailers when combined with a retractable Suzi cable (See page 24). It also includes our cable harness and lighting system 7 Core plug.

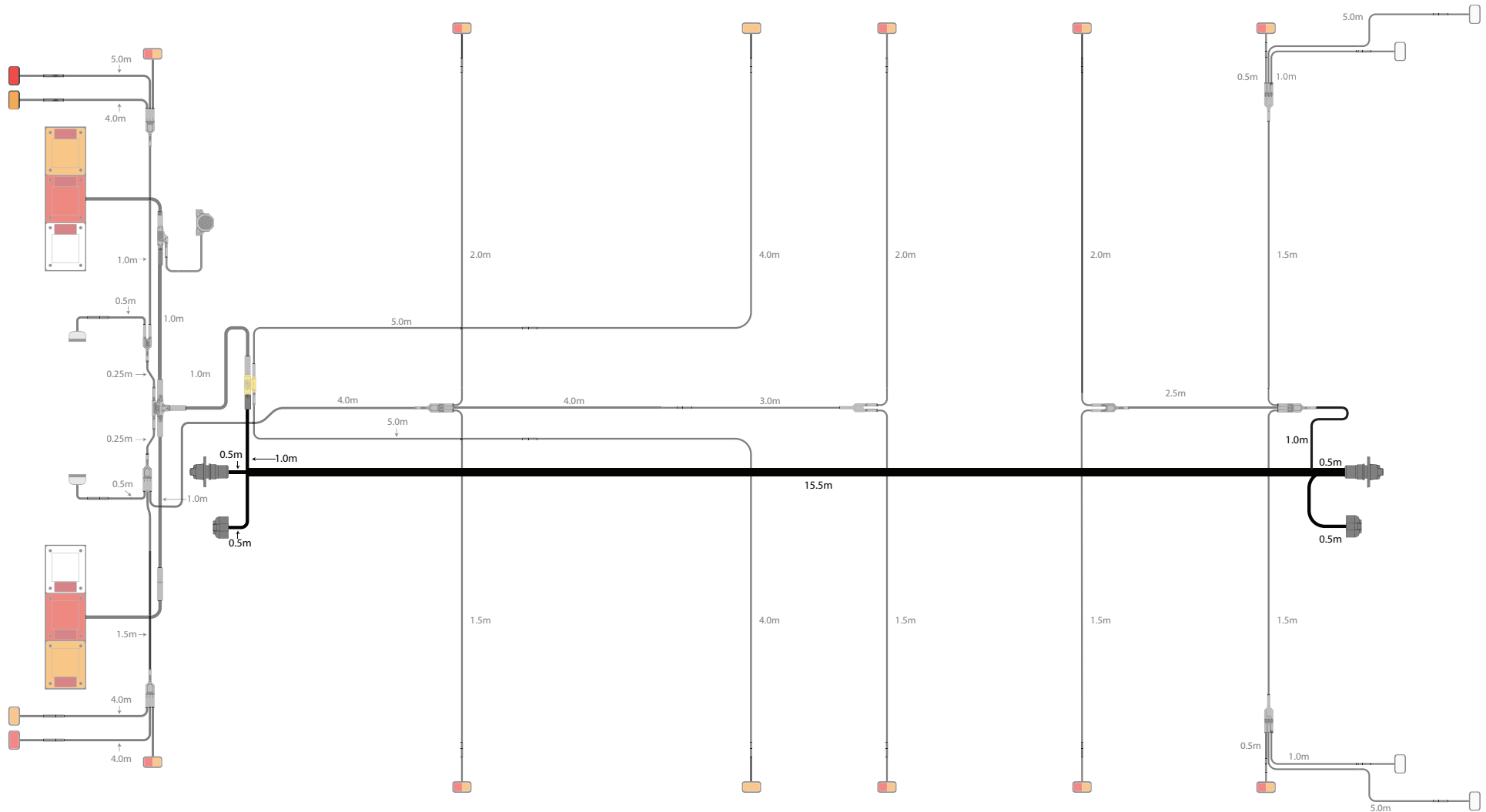

DROPDECK SCHEMATIC EXAMPLE WITH P/N 7CRTC-155M ROAD TRAIN CABLE

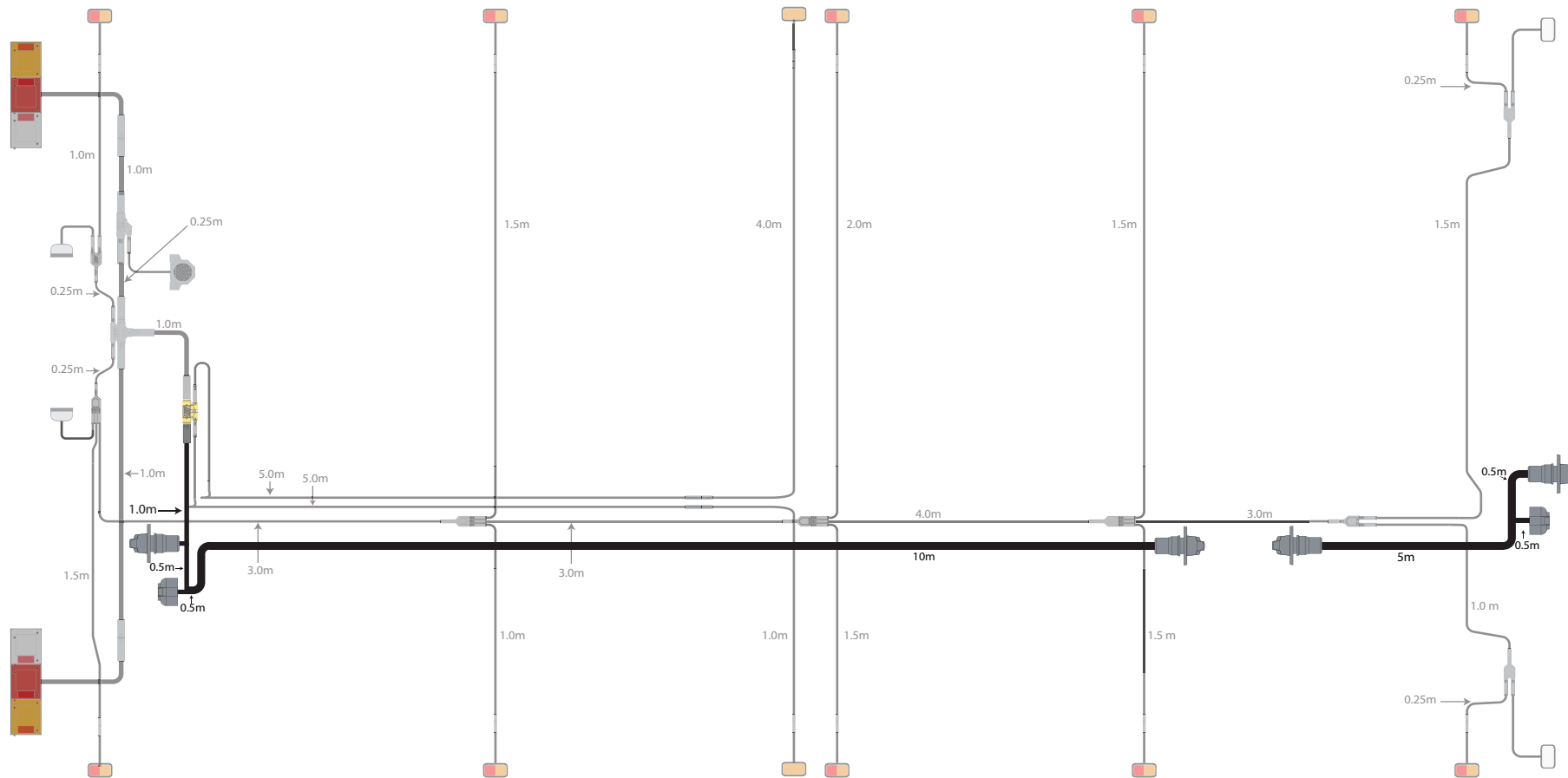

DROPDECK SCHEMATIC EXAMPLE WITH P/N 7CRTCRT-10-5M ROAD TRAIN CABLE



Part No.	Cable Function
7CRT-5M	5 METRES, 24V ONLY
7CRT-13M	13 METRES, 12-24V
7CRT-145M	14.5 METRES 12-24V
7CRT-16M	16 METRES, 12-24V
7CRT-155M	15.5 METRES, 12-24V

ROAD TRAIN CABLE FOR USE WITH RETRACTABLE SUZI CABLE. INCLUDES 12V & 24V 7 PIN SOCKETS AT BOTH ENDS WITH 2 CORE & 7 CORE PLUG ADAPTER.



Part No.	Cable Function
7CRT.RT-6-5M	6/5 METRES
7CRT.RT-10-3M	10/3 METRES
7CRT.RT-10-5M	10/5 METRES

ROAD TRAIN CABLE FOR USE WITH RETRACTABLE SUZI CABLE (SEE PAGE 24). INCLUDES 12V & 24V - 7 PIN SOCKETS AT THE REAR ALSO INCLUDES THE 7 CORE PLUG ADAPTER.



## **LED Autolamps**

439 Boundary Road

Truganina, Victoria 3029

Phone 1800 815 000

Email [led@ledautolamps.com.au](mailto:led@ledautolamps.com.au)

Website [www.ledautolamps.com](http://www.ledautolamps.com)

### **DISCLAIMER**

LED Autolamps has made every effort to ensure that the measurements and information contained in this catalogue are correct and accurate. Before orders are placed, especially before any commencement of manufacturing, please check all measurements and information. LED Autolamps reserves the right to improve, modify the dimensional design and or make technical changes or discontinue or update designs without prior notice. However, we will take all measures to inform our customers if and when possible of any changes made. LED Autolamps will not accept liability of any kind due to misuse or abuse of any products not used as intended.

**Printed May 2024  
Version 5.7**