

Forklift Safety Spot Lamp

100%
Water Proof

5 Year
Warranty

- Heavy Duty Compact Design
- Spot beam up to 2.5 metres
- IP67 100% Water dust proof
- 9-30 Voltage Range
- 5 Year Warranty

Function	Blue Forklift Safety Spot Lamp
Size	75mm x 93mm x 30mm
Voltage	9-30 Volt
LED Qty	2
Output	Spot Beam 2.5 Metres
Cable	40cm
Lens	Polycarbonate
Base	Die Cast Alloy
Draw	@13.8V @28V 0.285A 0.143A



7512BMB - Blister



The high brightness spot beam projects a blue light up to 2.5 metres. Visually alerting factory pedestrians that forklifts are operating in the area.

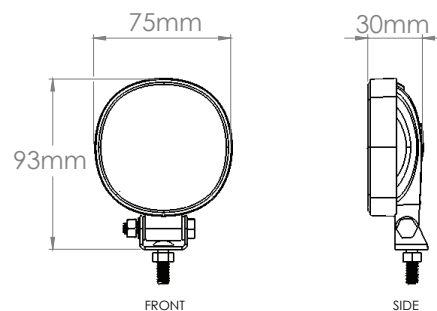

Fitting Instructions

Fix to mounting surface using stainless steel bolts and adjustable stainless steel bracket supplied.



All enquiries P: (03) 9466 7075 E: led@ledtech.com.au, www.ledautolamps.com

All efforts are made to ensure all information is correct and up to date, it can be subject to change without notice. All measurements are in millimeters (mm) and are not to scale.

© All LED Technologies designs are registered throughout the world. - Current as of 13/2/2017