

144 Series Strobe Beacon

SAE/J845
Class 1

100%
Water Proof

3 Year
Warranty

- SAE: J845 Class 1 Compliant
- High Powered 3 Watt SMD LEDs
- Strobe Rate 87 FPM
- Voltage Range 12-32V
- IP67 100% Water/Dust Proof
- 3 Year Warranty

Function	Warning Strobe Beacon
Size	130mm Round x 97mm
Voltage	Multivolt 12-32V
LED Qty	6 x 3 Watt SMD
Cable Fixed	19cm Sheathed
Flash Rate	87 FPM
Lens	Polycarbonate
Base	Nylon

	@13.8V	@28V
Draw	0.71A	0.28A



Inactive



Active

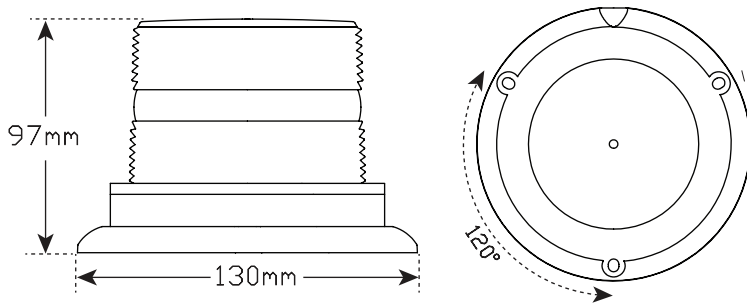

Fitting Instructions

Fixed mount - Run cable through hole in mounting surface, fix beacon using bolts supplied



Part No. 144AMF - Blister



All enquiries P: (03) 9466 7075 E: led@ledtech.com.au, www.ledautolamps.com

All efforts are made to ensure all information is correct and up to date, it can be subject to change without notice. All measurements are in millimeters (mm) and are not to scale.

© All LED Technologies designs are registered throughout the world. - Current as of 01/08/2018